

DIY-BOAT.COM • ISSUE #1 2009

DIY BOAT OWNER

THE MARINE MAINTENANCE MAGAZINE

Spring Fitting Out

Yard Do's and Don'ts
Making a MASTERpiece
Inboard Tune-Up
PFD Checkup
Underwater Bling
Bigger, Better Wheels
Swingin' with the Compass

U.S./CANADA \$7.99



WWW.DIY-BOAT.COM

Conversions made easy...

The Konrad PRS product line is the best alternative for the obsolete TR, TRS and SSM propulsion systems.*

The direct bolt-on replacement kit makes conversions easy with general experience required. Stop looking for used replacement parts. Apply new Konrad technology to your classic boat today!



- **Easy Installation**
- **Improves Overall Performance**
- **Cost Effective Solution**
- **No Transom Modification Required**

Konrad
HIGH OUTPUT PROPULSION SYSTEMS®

800-927-3545
www.konradmarine.com

* The TR, TRS and SSM are products of Mercury Marine, a Brunswick company. The name is used for reference purposes only.

COLUMNS

8 Scuttlebutt

Boat Smart: Whether it's classroom style or an online course, there are more ways to educate yourself in boating and boating safety. *By Patricia Kearns*

18 Diesel Engines

Losing Pressure: Cool-headed and logical thinking in the heat of threatening conditions helps. We can all learn from this boater's methodical approach to a mysterious engine problem. *By Harry Hungate*

20 Electrical

Electrical Signals — Was Anyone Listening?: Things are not always as they seem when it comes to diagnosing electrical problems. *By Alan Donn*

27 Shoptalk

All that's Silver is not...Stainless: Knowing what to select and how to properly install helps to eliminate the maintenance issues. *By Doug Cohen*

28 Electronics

Swinging a Compass: A GPS solves the mysteries of compass calibration, making it easier for you to swing your own compass. *By John Meskauskas*

31 Gear and Gadgets

Zen of Crew Communications: Hands-free, two-way communication devices are a great way to communicate without the theatrics. *By Garrett Lambert*

37 Sailboat Rigging

Prop Options: Select the proper propeller to maximize power performance and reduce drag. *By Bob Musselman*

46 Boat Handling

Boarding Assists: Some ideas for better holding, better footing, better hopping-all-around and safer boarding. *By David and Zora Aiken*

48 DIY Projects

Depowering an '80s Cruiser; Install a Teak and Holly Sole

56 View From The Stern

Odor Fatigue: Tips for tracking and controlling the microbial critters that produce the malodorous smells wafting from inside your boat. *By Roger Marshall*

DEPARTMENTS

2 Currents

Events, letters, news

4 Ask The Experts

Fitting Gas Inboard Filters, Problematic Fuel, Flushing Scale, Tank Repair Options, Random Start Westerbeke, Carbs and Fuel Economy, Smoke Suggests Failure, No Easy Fix, To Cover or Not?

10 Tech Tips

56 Issues of DIY



Technical reference library on CD-ROM.

Just \$99.95

To order call

1-888-658-2628

or order online at

www.diy-boat.com

See ad on page 55.

DIY BOAT OWNER

THE MARINE MAINTENANCE MAGAZINE

#1 - 2009

44



Spring Fitting Out

11 Making a MASTERpiece

Lessons learned from pros helps DIYers achieve a quality finish when restoring a mast to its original gloss. *By Nick Bailey*

15 DIY in the Boatyard

Recognize the hazards and minimize the risk of injury when working on a boat that is high and dry. Here's some advice from one DIYer who learned the "hard" way. *By Paul Esterle*

22 Underwater Bling

Adding underwater lights is a relatively simple improvement for your tender. *By Roger Marshall*

24 Ignition Tune-Up

For owners of older sterndrive or gas inboards often all that's needed to increase power and reduce fuel consumption is a breaker point ignition tune-up. Here's how. *By Steve Auger*

34 Top 20 DIY Web Sites

Cast off on a keyboard cruise and enter the land of virtual DIYing and explore how to let your fingers do the walking in a cyber-toolbox. *By Pat Kearns*

40 Inflatable PFD Service

Follow these steps to routinely inspect and service automatic inflatable PFDs. The life you save may be your own. *By Jan Mundy*

44 The Wheel Touch

A wheel upgrade to a soft touch makes helm duty much more enjoyable. *By Jan Mundy*

Compiled by Jan Mundy

Discovering Boating



Duma, a four-year-old Jack Russell Terrier and her owner Cliff Bode, made their Canadian wakeboarding debut at the Toronto Boat Show in January.

The National Marine Manufacturers Association and the Recreational Marine Research Center at Michigan State University have announced findings from a yearlong study demonstrating that attending boat shows is a crucial step in consumers' final decisions to purchase a boat. The study revealed that 55% of boat buyers attended a boat show within six months prior to their purchase. Of all the survey's respondents, some 65% agreed that attending a boat show

had increased their desire to purchase a boat.

As one who attends numerous boat shows every year, I'll attest to this study's findings. When we were looking to purchase a new boat, we first checked out the manufacturer's website for information and to find out about boat shows where we might see one in the "flesh." Lucky for us, the boat was on exhibit at an upcoming show nearby so we compiled our list of questions and eagerly awaited the show with great anticipation. But what if you're not in the market for a boat?

Show promoters try diverse marketing schemes to attract a broader range of consumers, particularly non-boaters, to come to boat shows. There was the water-skiing squirrel, shark jaws from a Frank Mundus kill, Gilligan from the '60s hit TV show "Gilligan's Island," the actor who played Q in the James Bond movies, the Batmobile and more recently, crew of the crab boat *Time Bandit* from the TV series "The Deadliest Catch." I've often wondered how successful such promotions, some of which seem totally absurd, are at selling boating. Now that would be an interesting study. I suspect that anything that grabs a viewer's attention is considered a suc-

cess if it distracts a person long enough to deliver the intended message. Some will get it; some won't. It's all in the numbers.

What's Zamac?

In the article titled, "Corrosion Savvy" in DIY 2008-#4 issue, the author refers to Zamac as zinc-coated steel. It's my understanding that so-called Zamac is a fancy name for pot-metal, which is the waste tin, lead and other stuff that is heated and poured into molds to make cheap fittings. To call it "steel" is overly complimentary. This does not take away from the author's point that Zamac doesn't make for durable marine components.

Gordon Cameron, Alexandria, Virginia

Pat Kearns replies: Actually, both of us are slightly off base but we appreciate the chance to set the record straight. ZAMAC is the acronym for an alloy composed of zinc, aluminum, magnesium, and copper. According to wisegeek.com, "Pot metal is a slang term used to refer to cheap metal alloys with a low melting point. The low melting point makes pot metal very easy to cast but the generally low quality can cause problems during

4 Easy Steps to Load a Pickup



- Step 1. Hook boat trailer to truck.
- Step 2. Drive really fast.
- Step 3. Hit light pole (needs to be a solid one) head-on.
- Step 4. Boat loads itself onto truck.

Note: the origin of this "tip" is unknown and we apologize if we have offended anyone.

ENTER TO WIN \$25,000

Could you use an extra \$25,000? Who couldn't!



From now until November, when you join BoatU.S., renew your membership or sponsor a new BoatU.S. or BoatU.S. ANGLER member, you'll automatically be entered to win \$25,000 in the BoatU.S. Wave of Fortune Sweepstakes.

In addition, you can increase your chances of winning \$25,000, or win weekly BoatU.S. gear or monthly prizes by simply playing the online *DockIt* game, a simulated test of boating skill. Log onto www.boatus.com/games to play.

The sweepstakes runs until November 30, 2009. For more

information, visit the BoatU.S. website at www.BoatUS.com/WaveofFortune, send an e-mail to Membership@BoatUS.com or call BoatU.S. Member Services at 800/395-2628.

casting and at a later date. Because there is no formal definition of pot metal, it can be hard to determine its contents. Some common metals included in pot metal alloys include: zinc, lead, copper, tin, magnesium, aluminum, iron and cadmium, among others." Thanks to our readers, getting caught with a little editorial egg on our face is always a good opportunity to dig deeper for the facts.

Emission Controls Now Law

The U.S. Environmental Protection Agency (EPA) has published new standards, effective 2010, for gas-powered marine engines. Apparently, these standards are the first national standards for boats powered by inboard engines and represent the first carbon monoxide (CO) standards for gas-powered engines used in recreational vessels. They are also the first to address the use of catalytic converters in smaller vessels.

Newly built vessels powered by gasoline engines must attain a 70%

Load Guide Trivia



Jan Mundy

reduction in hydrocarbons (HC) and nitrous oxide (NOx) emissions, a 20% reduction in carbon monoxide and a 70% reduction in fuel evaporative emissions.

The load guides purchased for our trailer arrived with no installation instructions. Mounting of the brackets seemed straightforward but positioning of the vertical posts against the topsides was an unknown. Are there guidelines to determine the optimum clearance?

An exhaustive search of the Internet found, surprisingly, nada. Using the power of the press, I contacted the trailer manufacturer and spoke with a technician who stated unequivocally that the industry standard is to have a 1" (25mm) gap. So we mounted them as recommended but have since reduced the gap to a closer 1/2" (12mm). The lesson here is that if someone states that a given method of doing something is standardized, try to find the reference. Some "standards" are found in accepted practice but they are not etched in granite anywhere.

The final rules represent nearly eight years of work done by the marine industry and EPA to test new technologies in order for marine engine manufacturers to meet the standards. 🔥

THETFORD
MARINE

*EasyFit*TM
toilet system

IMAGINE...

a compact marine toilet with elegant styling and powerful performance!

- ▶ **Vitreous china bowl** for maximum flush performance and easy cleaning
- ▶ **Saves water** and limits clogging by immediately macerating waste
- ▶ **Completely self-contained** to save space and installation time—and no more external pumps and macerators!
- ▶ **Small footprint** easily accommodates pre-molded boat bathrooms

Ask for Thetford Marine



www.thetford.com

Fitting Gas Inboard Filters



Pat Kearns

Always consider safety first when modifying gasoline fuel systems.

Q: I've replaced most everything in my Silverton's engine compartment, including the twin gasoline engines, fuel tanks and lines. I'm now putting in new filter housings and filters and am considering mounting filters with clear see-through bowls so I can easily identify any foreign matter in the fuel. I've read everywhere that on gas inboards you must use the ones with metal bowls. I've asked several people why this is but nobody can give me a definite answer.

Capt. Vincze, Ft. Lauderdale, Florida

A: Both the U.S. Coast Guard (USCG) and American Boat & Yacht Council (ABYC) requirements for gasoline fuel systems for boatbuilders and component manufacturers require that fuel system components pass a "fire test." The methods for performing the fire test are found in the USCG code and in the voluntary ABYC Standard H-24, Gasoline Fuel Systems. These tests are not for amateurs or even experienced DIYers so I will not go into any detail about them and the tests are required to be performed in pursuit of certification of the results. Suffice to say, anything that you install in your fuel system should be certified that it meets the fire test, with few exceptions.

The standards do not prescribe or limit materials. The standard simply says that the material you do use must be able to withstand the fire test. If a material can stand the heat, so to speak, and is certified that it has been tested to do so, you can use it. In the case of gasoline fuel filter bowls, the easy answer is to use metal. However, even the metal filter bowls and housings have to survive

the tests, along with their gaskets and other assemblies.

When your boat comes under the scrutiny of a marine surveyor, either at point of sale or when your insurance company demands a survey, your choice of less than what complies with ABYC could result in a repair recommendation. Marine insurers want to see that the fuel system complies with the minimum standard. If you don't insure your boat and you have an accident that could have been prevented by compliance, you may be in an expensive line of liability for property damage or personal injury caused by the accident. Gasoline fuel system failures have caused tragic fires and explosions. In any case, any responsible boater should want to do what has been set as the minimum in safety practice.

Gasoline is volatile stuff and, even without the presence of liquid fuel, the vapors alone can turn a boat into a bomb. Small amounts of liquid gasoline leaking from a remote fitting can be the source of explosive vapors that will seek the lowest point in your boat's bilge. All that is needed is a point of ignition to ignite the vapors for a destructive explosion and/or fire. The bottom line for your concern is "safety first." You will have to make some decisions about the advantages of a clear fuel view versus the hazards of an error in engineering the fuel system that results in a leak. I do not believe there are any such products. American National Standards Institute and Underwriters Laboratories 1105 is the test standard so any filter marked as complying with ANSI UL 1105 is acceptable.

— Pat Kearns

Problematic Fuel

Q: My boat has twin 228 Mercruisers and twin fuel tanks and any engine troubles I have seem to be fuel related. Each engine has a carburetor filter and spin-on water/fuel separator filters. I'm considering installing primary and secondary Racor filters on the main fuel line or does each tank need a separate set-up? Do I remove the other filters after the Racors are in and what size micron filters should I purchase?

Wade Jurke, Vanderhoof, British Columbia

A: First some background on today's fuels. The storage life of the newly formulated fuel blend (E-10 equals +/-

10% ethanol) that you pump into your boat's fuel tank is only a few weeks and this causes a number of problems. EPA mandated additives, such as alcohol, methanol and dispersants, can cause fuel systems on marine engines to experience a number of failures from water contamination to stuck floats and inlet needles in carburetors as well as seized electric fuel pumps and fuel line degradation. Adding additional filters should not be necessary if you are using Mercruiser original replacement parts. These filters adequately protect the system from water and debris and adding more filters won't stop the degradation of the fuel. Using a quality fuel stabilizer during the boating season and draining the fuel tanks for long-term storage is presently your best bet toward preventing fuel system failures during the boating season.

Racor does not rate most of their filters by micron but rather by fuel flow. Your engines can consume around 30 gallons per hour (gph) each so, if you are going to change the filter system to a single filter, you need at least a 60 gph filter and I recommend a 90 gph or higher rated filter so as not to increase the vacuum on the inlet side of the fuel system, which can cause vapor lock. The maximum amount of vacuum allowed is 2hg of vacuum measured at the spin-on fuel filter inlet. Also, mount any fuel filter as low in the engine compartment as possible as this reduces the possibility of vapor lock due to increased fuel temperature through engine compartment heat that is soaked up by the filter after a run. Always check for fuel leaks after installing any fuel system component.

— Steve Auger

Flushing Scale

Q: I'm considering flushing my Perkins 4-108 to remove the scale that has built up inside. What method do you recommend?

Mike McKee, Cobbs Creek, Virginia

A: The correct way is to remove the heat exchangers and oil coolers (engine and transmission). Removal is very straightforward with hand tools. Replace any system components and/or oil coolers that are older than 10 years or have turned a pink color (corrosion) at fittings or have been weeping at any soldered joint. A radiator shop or Perkins dealer can help

you with the inspection. Replace old hoses and expansion caps now as well. The product used to clean exchangers is usually a muriatic acid cooling system flush, which is readily available but toxic and requires a bathing tank to do the job. Seawater never sleeps and these system components don't last forever. They can be cleaned but, if not professionally done, the act of cleaning alone can shorten their productive life.

— Randy Renn

Tank Repair Options

The 200-gallon freshwater tank, located in the aft storage area, has a slow leak. I finally located a wet area on the starboard side of the water tank, from the front to just midway to the aft side of the tank, and drained the tank. There is good access to effect a repair in this area rather than replacement that, according to the yard's service manager, would be very difficult and expensive. He suggested applying some type of resin to the inside seam where the welds have corroded. My thought was to apply stainless-steel angle, assuming I can make room for it on the bottom edge of the tank, held in place with J-B Weld.

Robert Van Gemert, Rockford, Michigan

A: Unfortunately the only guaranteed solution to this leak is to remove and replace or reweld the tank. If you decide against that, you are entering the world of compromise solutions that may or may not work. It's possible to coat the inte-



Corrosion along the weld lines created pinhole leaks in this freshwater tank.

rior of the tank with a tank liner epoxy. I assume this is what your service manager was referring to and it offers a reasonable chance of success. Devoe Coatings manufactures a food grade epoxy specifically designed for this application known as Bar-Rust 233H (www.devoecoatings.com/Markets/wastewater.jsp). This coating is designed to be somewhat tolerant of less than perfect surface prep but, at a minimum, it still requires aggressive cleaning with an etching solution or possibly even sanding. Using J-B Weld, Marine-tex or other popular patching compound may work or may not. If the patch compound is waterproof enough to keep the water away from that seam and flexible enough to avoid cracking as the tank flexes, so far so good but I have my doubts. Once again the adhesion of the patch would depend on the quality of the surface prep. Remember that most of the cost of putting in a new tank is the labor to access and remove

the old one. The cost of the new tank is only a small percentage of the cost of the job. You might consider installing a tank within a tank. If there is decent access, it is probably feasible to install one or more Vetus bladder tanks (www.vetusmarine.com/ccp0-catshow/Flexible+Tanks+%3A++Drinking+Water.html) within the existing tank. This approach requires some significant plumbing revisions and reduces your water capacity. There is no benefit in trying for the potentially false economy of a tank repair.

— Nick Bailey

Random Start Westerbeke

Q: The starter motor on my 100hp Westerbeke diesel acts like it has a bad solenoid. I replaced the starter/solenoid (many times), all switches, batteries and battery cables (1/0). When I push the start button, I get a click. After several tries, the starter engages. It doesn't matter if the new battery switch is on "One" or "Both" batteries. I don't know what it could be other than a bad solenoid but this has been replaced several times.

Don Robbins, Hilton Head, South Carolina

A: DIY contacted Joe Joyce, Westerbeke's service manager, and received this response: "What the owner is describing is typical of a DC voltage drop in the start circuit at the activation connection on the starter solenoid. Place a voltmeter between this connection and the engine ground when this clicking takes place and measure the DC voltage at the activation terminal. I would suspect it to be 8.5 volts or 9.0 volts or much less. Next, check that all connections at the plug connector of the engine harness to the panel harness are clean and tight. If the instrument panel is more than 15' (4.5m) of harness away from the engine, there would be a second extension harness in the circuit giving two more plug connections. If this is the case, I suspect a slave relay is needed for the activation connection of the starter solenoid. Next, check the start button in the panel. Contacts inside the push button may be pitted and corroded and not allowing a good contact when pushed, resulting in a voltage drop across the switch. Also, the slave relay, if equipped, could be dirty or defective."



I TOLD YOU NOT TO FORCE THE PROP ON WITH A SLEDGE HAMMER!

Sacha

Carbs and Fuel Economy

Q: My 1988 Carver Mariner has twin Mercruiser 5.7L, 260hp Bluewater inboards and Thunderbolt 4 ignition. The Rochester Quadrajets four-barrel carburetors are leaking a little and I can buy remanufactured units for between \$450 and \$600 or have the old ones rebuilt at half the cost at a local carb shop. Will I get better gas mileage with new carbs?

— Murray Abbott, Toronto, Ontario



Jan Mundy

A dirty hull bottom has a direct impact on fuel economy.

A: First of all, leaking gasoline anywhere on a boat is a high risk hazard and must be dealt with immediately as an emergency. Don't use the boat again until you have repaired the problem. A remanufactured carb provides the same amount of fuel delivery in gallons per hour (gph) as an identical new carb with the same jet and metering rod combination. Normally, carbs are replaced with new or remanufactured ones if the throttle shaft bores have worn out, which causes an unwanted air leak. If the carb is not worn out, corroded or damaged, then a Mercruiser rebuild kit works just fine installed in the original carb by an experienced rebuilders. Rebuilding a carb is not a DIY repair and is best left to a pro. Also, make sure that, with any repair or service to the fuel system, you are using parts that are designed for a marine application. They will be marked with that assurance. Automotive parts do not have the critical safety components required by marine grade parts.

There are some steps that can improve your fuel consumption. Reducing the boat weight is the first step. Clean out the storage lockers and remove all gear, such as old lifejackets, beach toys, "stuff" and accumulated flotsam and jetsam that is not required for every trip. Keep the bilge as clean and dry as possible; boats can

gain weight from water that migrates into bulkheads, stringers, etc. Fill potable water tanks with only the amount of water needed for the day's cruise and don't wait until the waste tank is full for a pump out. Keep the engines in tune and back off on the throttle. Cruising in the 3,000 rpm to 3,500 rpm range saves 35% on fuel consumption versus running at 4,200 rpm. Lastly, keep the hull clean below the waterline.

— Steve Auger

Smoke Suggests Failure

Q: While changing the oil on my '76 vintage raw-water cooled Yanmar I noticed some frothing in the oil. Earlier, I noticed, for the first time, some white smoke when running the engine at top speed. A competent mechanic in Florida some three years ago overhauled the engine. Do I need to change the head gasket? There are no reliable mechanics where the boat is currently berthed, ergo I will do the job myself.

Bruce Richardson, Chance Encounter, Gloucester, Ontario

A: White smoke is surely one sign of a possible failed head gasket. At this point a 1976 seawater-cooled engine could simply have corroded through at some point. To confirm a failed component, lock off the seawater inlet and exit hoses and lightly pressurize the system to about 10lb (4.5kg) and watch for a pressure drop. Be sure to look at the exhaust manifold and elbow as sources of smoke and slight water ingestion. Regardless, do not run the engine with water in the oil.

Before continuing, you'll need a workshop manual for your engine. Now inspect the injectors. Be careful not to bend any lines, lose any washers or misplace any fasteners. Muffin tins work well as do plastic food storage bags and labels for storing parts. The cleanest injector will be the one where the gasket has failed or the cylinder head has cracked or corroded through. In a worse case scenario, it's possible that the head has warped. Tools required for this job include torque wrenches in foot and inch lb, socket and open-end wrenches, ring spanners and, ideally, crows foot line wrenches as well. Consult with your local Yanmar supplier about gasket sets, O-ring parts, oil filters and spares. Remove the cylinder head bolts in the reverse order in which they were torqued down and remove them gradually in increments of 15lb per

DIY Boat Owner™
The Marine Maintenance Magazine™

P.O. Box 22473
Alexandria, VA 22304

Publisher: Nancy Michelman

Executive Editor: Elaine Dickinson

Editor: Jan Mundy

Advertising Sales Manager: John Bratten
703/461-4389/jbratten@BoatUS.com

Technical Editor: Patricia Kearns

Circulation: Susan Clark

Designer & Illustrator: Joe VanVeenen

Cover Photo by: Billy Black

Contributors:

David and Zora Aiken, Steve Auger, Nick Bailey, Alan Donn, Paul Esterle, Jim Grant, Harry Hungate, Garrett Lambert, Roger Marshall, John Meskauskas, Bob Musselman, John Payne, Paul and Sheryl Shard.

Director of Advertising:

Steve Kalman 888/658-BOAT (2628), ext. 2
E-mail: stevek@diy-boat.com

REQUEST A MEDIA KIT

www.diy-boat.com

Subscription Inquiries:

Call 888/658-BOAT (2628) weekdays 8am to 5pm EST or log onto DIY ONLINE: www.diy-boat.com

Subscription Rates:

1 year (4 issues)	\$25
Canadian residents	add \$5
Foreign residents	add \$25
EZINE (web version) 1 year	\$15
Payable in U.S. Funds only	

DIY Boat Owner #1 Spring Issue 2009: DIY Boat Owner, ISSN #1201-5598 is published quarterly by Boat Owners Association of the United States, 880 S. Pickett Street, Alexandria, VA 22304-4695. Periodical postage paid at Alexandria, VA and additional mailing offices.

POSTMASTER: Send change of address to DIY Boat Owner, PO Box 22473, Alexandria, VA 22304-2473
DIY Boat Owner™ and The Marine Maintenance Magazine™ are registered trademarks.

©No part of DIY Boat Owner magazine may be reprinted or used without the express written consent of the publisher. All materials contained herein are copyrighted and all rights reserved.

While all precautions have been taken to ensure accuracy and safety in the execution of articles, plans and illustrations in this magazine, the publisher accepts no responsibility for accidents, material losses or injuries resulting from the use of information supplied in these articles, plans or illustrations.

Printed in USA

MEMBER
ABYC
Setting Standards for Safer Boating



WE FOLLOW BOA'S ETHICS GUIDELINES

loosening step. Consult your manual for all torque specifications.

Consider that replacing a cylinder head without doing a valve job, seal replacement and bore reconditioning is somewhat akin to replacing your tires without balancing, alignment and new air. The best approach is to purchase a reconditioned head as reconditioning one onboard is tough business requiring machine shop skills. Fortunately, these engines are readily available and are nearly indestructible.

— Randy Renn

No Easy Fix

Q: My seven-year-old 2.7m Quicksilver Hypalon dinghy has been stored (rolled up) in my garage for the past couple of years. When I inflated it this season it seemed okay at first, but after a few uses the glued seams started coming apart. It was suggested that the damage happened because it had been deflated for so long. On getting quotes for fixing the damage I was amazed to hear that this requires a professional repair job that costs \$600. Any suggestions and

techniques on how I could do the job myself?

Michael Portelli, Malta

A: I've not heard of deflating during storage as reason for seam delamination but, without sound seams, you'll never be able to maintain pressure. The price quoted seems fair given the amount of work involved. If the repairer is willing to guarantee its work and fix any leaks, it's even better. I'm not aware of any DIY repair options.

— Jan Mundy

To Cover or Not?

Q: Should you or should you not cover your fiberglass boat for winter storage? We have a 31' (9.4m) Concord cabin cruiser. Opinions from the boatyard "talk" are mixed.

Linda Murphy, Baltimore, Maryland

A: It's a very easy choice if you consider a few simple factors. During the winter the UV rays from the sun continue to deteriorate the gelcoat, breakdown any bright-

work coatings, craze plastics etc., just as it does in the summer. Add this to the environmental pollutants and, by not covering your boat, you have doubled the exposure, doubled the maintenance and reduced the life span of coatings and plastic components. If you have any cracks in the gelcoat it's possible that the winter's freeze/thaw cycles can expand those cracks, causing water to get into the fiberglass laminate...and so the cycle continues. Invest in a good boat cover or shrinkwrap your boat (except painted boats), provide good ventilation and hang DampRid bags to eliminate condensation and the resultant mildew and, in the spring, you'll have a cleaner boat that's in as good a condition as when you put it to bed in the fall.

— Jan Mundy

ASK THE EXPERTS
is a FREE Helpline for
DIY Subscribers



To subscribe go to
DIY-BOAT.COM

DAVIS

More Fun in the Great Outdoors!



Doel-Fin®
The original hydrofoil!

Improves performance on any boat. Increases fuel efficiency up to 30%. Higher top speeds, greater stability. Over 1,000,000 sold.



Inflatable Key Buoy™

Never lose keys in the water again! When Key Buoy falls in the water, an air tube automatically inflates, carrying your keys to the surface.

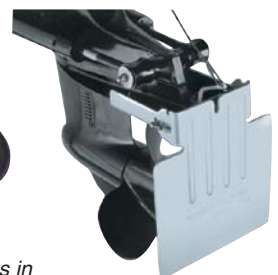

Happy Troller®

Slows even big motors down to that "ever-so-slow" fish tantalizing speed. Your boat's stability is enhanced at cruising speeds, too.



Air-Dryer™

An inexpensive and effective way to fight mold, mildew, moisture, and corrosion. Silent, low-cost operation.



Knot-a-Bag® Plastic Bag Dispenser

The most convenient plastic bag—anywhere! Unique dispenser lets you make bags of any length.

FSR™ Fiberglass Stain Remover



Specially formulated for removing oil, rust, exhaust, waterline and transom stains. The best there is!

Vantage Pro2® Wireless Weather Station

Breakthrough technology transmits weather data wirelessly 1000 feet! Large LCD display; sensor suite measures rain, temperature, humidity and wind.



Davis Instruments

3465 Diablo Ave., Hayward, CA 94545 U.S.A.

800-678-3669 • sales@davisnet.com

www.davisnet.com

BoatSmart

When “I’ve always done it this way” isn’t enough, where can you turn for more structured training? Classroom style or an online course, there are more ways than ever before to improve your boating knowledge.



By Pat Kearns

United States Coast Guard (USCG) statistics on 7,700 documented boating accidents show that nearly 70% of the incidents resulted from operator error. Of those operators, more than 80% admitted they had no formal boating education. The knowledge deficit was a factor in operator ability to anticipate and identify hazardous situations and compounded by the fact that those operators didn't know what to do when they were faced with an obvious threat to their safety onboard, putting themselves and others at risk.

Some level of mastery of boat operation will inevitably be complicated by weather, navigation puzzles, rules and regulations,

mechanical problems, and other boats and boaters. New situations develop all the time and that's part of the delight of boating. If you know what to do and how to handle yourself and your boat in the ever evolving marine environment, you are rewarded with constant experiential growth.

The U.S. has no nationwide education requirement but allows each state to set its own laws and the majority of U.S. states now have a statutory requirement that boat operators take and pass a boating safety course. The courses required cover the basics but do not test for operational skills on the water. For a

list of courses that are accredited with the National Association of State Boating Law Administrators (NASBLA), the organization that sets U.S. education standards for state boating programs, go to www.nasbla.net/courseListing.php.

The states that do mandate courses often start the requirement with boaters born after a certain date. By attrition, over time, this will include all boaters in these states. Boaters born prior to their state's "start" date are grandfathered in but they are encouraged to take the courses and many do.

In Canada, all persons 16 years and older operating a motorized vessel, must pass a safe boating certification test and have a valid Pleasure Craft Operator Card as of September 9, 2009; restrictions apply for persons under 16 years old.

Home Study

Want to learn more about boats and boating? The BoatU.S. website (www.boatus.com) is the mother lode of recreational boating resources with a NASBLA-approved online boating safety course that meets the requirements of 31 states.

The home page for the BoatU.S. Foundation's Online Boating Safety Course (www.boatus.org/onlinecourse) has a list of states that accept this course for their mandatory education law, plus a map guide to all state requirements, a review course with links to glossaries and additional information to study, and a "final" exam of 75 questions. If successful, you can print out your own certificate. This course is free.

Build your basic skills and then move on to links to just about "everything you ever wanted to know about ... but were afraid to ask." There is a guide to buying and selling, the Boat Tech guides, How To guides, a Consumer Protection Bureau, Boat Groups forums, boat design reviews and *DockIt*, an online-based video game that challenges the user to maneuver a virtual boat in the kinds of scenarios that often don't lend themselves to practice time.

Traditional classroom-based courses, such as those offered by the USCG Auxiliary (USCGA) or United States Power Squadrons (USPS), still form the learning base for most entry-level boaters. In addition to the basic boating class, the volunteer groups also offer seminars on navigation, radio usage, weather forecasting, boat han-

ding and more offered at any of the following websites: USCGA nws.cgaux.org/visitors/pe_visitor/index.html; USPS www.usps.org or the Canadian equivalent www.cps-ecp.ca. Many states (and provinces) also hold classroom boating safety classes.

While the traditional classroom has the unique advantage of being able to interface with the instructor and other students, online and distance learning training is getting closer to that experience all the time with live and interactive audio and video that includes real time, personal encounters. Kick off your Topsiders, grab your laptop and sign up for an online program that you can take from your recliner. America's Boating Course is an interactive, PC-based, home-study course for those who cannot attend a classroom course. Sponsored by USPS, the course uses guided instruction and videos and audio clips to convey its content and a textbook is included with the course. The final exam is proctored by a USPS member and is scheduled as near to your location as possible.

Your local library probably has a section of its video collection that is devoted to recreational boating. I scouted out www.amazon.com and found lots of boating videos, many of an instructional nature.

Reality Training

Formal training in the "hands-on" skills, e.g., docking, anchoring, navigation (chart based), and using the Rules of the Road in actual practice underway is a bit more challenging to obtain but since this is where the hull hits the water, so to speak, it's a key part of skill building if you're going to become confident and expert in operating a boat, small or large.

You can ease those on-water stresses by enrolling in onboard classes or private instruction offered by individuals or companies that specialize in this type of training. Often a yacht broker, your marine insurance agent or staff at your nearby West Marine store know of individuals who are experienced, sea wise and who have a gentle way of sharing their knowledge, many times onboard

your own boat. This kind of learning does not come cheap but it might be the best investment you'll make to equip yourself with can-do confidence. Offshore Sailing and Powerboat schools are a good example of on-board training courses (www.offshore-sailing.com).

Check "The Mother of All Maritime Links" at www.boat-links.com/linklists/boatlink-39.html, where I found more than 100 links to sailing and boating schools. Google "power boat schools" or "sailboat schools" and you can cyber-navigate your way to a personal learning experience that could save you years of learning at the school of hard knocks and the ego bruises that can go along with it.

From basics to advanced skills, there is something for everyone who wants to become proficient and gain confidence in their boating skills. What price competence? To quote Nike: "Just do it." 🚩

About the author: Pat Kearns is a marine surveyor and DIY's technical editor. She operates Recreational Marine Experts Group, a survey and consulting firm in Naples, Florida.

YOUR DISCOUNT SOURCE!

Briter Flush Mount Underwater Lights Feature:

- Marine grade 316 stainless steel
- Surface mount
- Installation is a snap
- Only one 1/4" hole for wiring
- Our brightest flush mount underwater light

NEW!



Bay Underwater Light

- 3-1/2" diameter x 5/8" height
- 450 lumens
- Only .65 amps, 10.5-14V

700463 (White), 700464 (Blue or Green)

SALE \$279.99

Canyon Underwater Light

- 4-5/8" diameter x 1-1/16" height
- 850 lumens
- Only 1.8 amps, 10.5-30V

700466 (White), 700467 (Blue or Green)

SALE \$495.99

NEW!



Sale prices expire 3/15/09

THE BRANDS YOU WANT AND TRUST IN STOCK FOR LESS!

Defender®

www.defender.com

800-628-8225 • info@defender.com

Most Orders Ship the Same Day!

FREE Catalog!



MONITOR

Fresh Water Cooling Systems

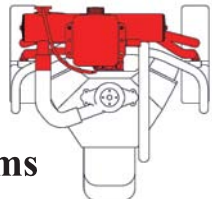

NEW
Easy Do-It-Yourself
Conversion Kits

Ultimate Engine Protection
Lower Fuel Consumption

Cooler by Design

www.monitorpro.com
Call 1-800-334-4591
MONITOR PRODUCTS, INC.
15400 FLIGHT PATH DR. BROOKSVILLE, FL 34604

Seeking Boat Repairs or Maintenance?
Make sure it gets done right...

Visit www.abycinc.org to locate an **ABYC** Certified Technician!



Boating Safety...It's All About Having Fun.

ABYC 613 Third Street, Suite 10, Annapolis, MD 21403
P- 410.990.4460 • F- 410.990.4466 • www.abycinc.org • www.westlawn.org

Tech Tips

When the Stop Fits:



When you need a drill stop, take a piece of doweling larger in diameter than the drill bit and cut it to fill the distance between the length of the drill bit and the depth you want to drill then drill out the middle and slide over the bit.

Graham Collins, Tardis, Halifax, Nova Scotia

More than Wire:



Heat-shrink tubing, commonly used on electrical wires, comes in a multitude of colors, including

blue, green, pink and yellow. Use it to "whip" line ends and color-code the tubing to match the tracer color in the lines to quickly identify control lines that lead to the cockpit.

Fresh Scent: To keep clothes fresh, place fabric softener sheets in hanging lockers and drawers.

No Moving Parts: Simple yet effective "latch" — with absolutely nothing mechanical that might fail — is a magnet closure to hold lightweight hatches in the raised position when required.



Jan Mundy



Jan Mundy

Gasket Care: When was the last time you changed the gasket under the fuel or water tank fill caps? A cracked gasket is the single largest cause of gradual water ingestion into the fuel system and, at the water tank inlet, it's a source of contamination invading the potable water supply. Inspect exposed gaskets every time you open the caps and replace gaskets proactively.

Pressure Guard: Since most marinas have city water pressure that exceeds 35 psi, if you leave your boat connected to dockside "city" water, protect your boat's potable water system components by installing a water-pressure regulator on the water hose end or water inlet. This reduces water pressure down to 35 psi. Never leave your boat unattended with the dockside pressure water feed on. There are lots of boat floodings on the books because of the failure of hose, a connection, etc. within the potable water system onboard that went unnoticed as the pressurized water from the dockside hookup flowed into the boat undetected.

Clean then Polish: After cleaning toilets, sinks and shower compartments, let dry fully then apply a light coating of polish or wax on the surfaces. This helps keep them clean, minimizes maintenance and guards against rust on stainless-steel components.

Diesel Clean up: Use a solution of white vinegar, water and hand washing dish detergent to clean diesel fuel or kerosene spills from bilges and floorboards. Dab fabrics with a sponge dipped in straight vinegar but first do a compatibility test in an inconspicuous place.

Plumbing 101: As a basic plumbing rule of thumb, Teflon tape all plumbing fittings that do not have a rubber O-ring and, conversely, never use Teflon tape on fittings that have an O-ring.

Randy Renn, Stevensville, Maryland

Fabric Shield: Routinely spray upholstery, throw pillows and carpets with Scotchgard to repel spilled liquids and stains. Before applying, be sure to read the instructions and warnings on the container and test an inconspicuous area first.

Sizing Docklines: Longer docklines make it easier to control your boat in strong winds and current. When purchasing new docklines, consider these sizing guidelines. For bow and stern docklines, buy lines that measure one and a half to two times the beam of your boat; purchase springlines the length of your boat; carry two longer lines two to three times your boat's length; and for storm use, purchase lines two sizes larger than fair weather lines, e.g. 1/2" lines become 5/8" or 3/4".

Although reader tips are accepted as submitted in good faith, DIY has not tested or proven those tips. DIY offers no guarantee or warranty as related to their fitness or suitability for service or application as reported.

TECH TIPS WANTED

Published tips receive a BoatU.S. Canvas Bag



The perfect accessory for holding your boating gear, water bottles and other gear. This bag also easily turns into a backpack for hands-free carrying.

Just send us a description of your boat-tested tip or technique, along with a photo (if available), your name, boat name and homeport to:

DIY TECH TIPS

P.O. Box 22473, Alexandria, VA 22304
or E-mail to: tech@diy-boat.com



Making A MASTERPIECE

Lessons learned from pros helps DIYers achieve a quality finish when restoring a mast to it's original gloss.

Every job starts with a request for a quotation and spar paint jobs are no exception. In this case, a wishbone and an external sail track mean factoring two booms and coping with countless seized screws.

Story and photos by Nick Bailey

Most sailboats built within the last 30 years arrived from the factory with aluminum spars either anodized or painted with a two-part polyurethane finish. These gleaming coatings are very durable but, like everything else in life, do not remain beautiful forever. So an important, though oft neglected, part of any mid-life sailboat makeover should be refinishing the spars.

Sticker Shock

Before anyone decides to replace that chipped and flaking paint or dull anodizing with a gleaming new polyurethane coating, the number one question must be answered: how much? A typical price for spar refinishing is around \$100 per foot (305mm) of spar length so if you have a 50' (15m) mast and a 13' (4m) boom that translates to around \$6,300 for the paint job itself. This price probably does not include the cost to derig the boat and unstep the spar or remove and reinstall all the fittings and hardware, the "re and re" as it is affectionately known. Those additional costs can run the price to \$150 per foot (305mm) and beyond.

Many people are surprised that this "all inclusive" spar refinishing price is compa-

nable to the cost of refinishing the hull. After all don't the spars have 25% to 50% less surface area? Why so expensive? The primary reason is that labor costs are higher relative to the surface area due the fact that a spar involves more detail work than prepping the wide-open expanses of a hull. There are also no significant savings in material costs due to the losses in spraying a smaller target.

When estimating labor costs for refinishing a given spar, a pro shop often assumes one hour of labor per foot (305mm) for the basic paint job and then adds an additional labor allowance for hardware re and re. This surcharge varies depending on the number of fittings and the condition of the spar (i.e. the amount of corrosion) but easily adds an additional 50% (or more) to the labor cost. Thus the \$150 per foot (305mm), "all inclusive," price tag.

After recovering from the initial sticker shock, the next question is, "To save money, can I do this job or some part of it myself?" Many yards are happy to let the customer handle derigging and rerigging as well as the painful job of hardware re and re. Some yards may allow the customer to strip the old coatings but most will want to do all of the prep and paint-

ing to maintain quality control and ensure compliance with applicable environmental standards for controlling dust and vapors, in addition to those standards covering the safety of personnel doing the work. It is possible for a reasonably skilled amateur to do the whole job but it's very time consuming. However, recent improvements in two-part urethanes designed for brush application by amateurs (Interlux Perfection is a good example) allow a DIY application to approach the perfect gloss of a professional spray paint job.

The Professional Approach

Here is how one professional yard, Bristol Marine Ltd. (on Lake Ontario near Toronto), where I'm the general manager, refinised the spars of a 1978 Hinterhoeller Nonsuch 30 catboat.

Step 1: Evaluating the Job

Before providing a firm estimate, a visit to the boat is needed to get a general idea of the condition of the spars and existing coatings. This boat has a wishbone boom plus an external sail track attached with a zillion machine screws. Hardware re and re will definitely involve a surcharge. A worn spot on the wishbone reveals two



A close inspection of a chafed spot on the wishbone shows a good base with two layers of paint and primer. This will be the boom's third overcoat paint job.

well-adhered layers of existing paint and primer that may only need a good prep sand prior to topcoating. The paint on the mast, however, shows some adhesion issues related to corrosion so many areas will need to be stripped, primed and filled. The estimate goes out at standard pricing with hardware removal extra. The customer volunteers to remove as much hardware as he can.

Step 2: Hardware Removal

The customer has had some success with the wishbone hardware but, as expected, many of the mast track fasteners won't budge, so the spars are moved into the shop and we take over the re and re. We take a series of digital pictures and save them to assist our recall of where things go when it's time for reinstallation. Some seized screws are drilled out; others end up having their heads ground off and are left behind like flush rivets. We avoid the heat and penetrating oil technique. It's not so effective on small fasteners and introduces contamination to a surface that must be kept absolutely oil free.

Why remove the hardware at all? Can't it be masked? Yes it can, but that also takes time and results in an inferior paint



The spars are moved into the paint shop and fastener removal begins. Master technician, Earl Hadcock, starts by removing the few movable screws using a battery powered screwdriver but finishes the process using a grinder to buzz the heads off seized machine screws.

job with a shorter life expectancy. Over time, moisture creeps, one molecule at a time, under the formerly masked edge of the coating and causes corrosion in the anaerobic environment under the paint. The ideal paint job creates a seamless seal so you remove everything you can. Unfortunately, in some circumstances there is no choice but to mask any unremovable fittings.

Step 3: Prep Sanding

Once all hardware is removed, the spars are cleaned and degreased with solvent and examined in detail. Cracks that require welded repairs or problem areas that require stripping to bare metal are marked with a pencil. (Never use a marker pen as it will print through.) The question of whether or not to strip the previous coatings is an important one. Two-part paints generally cannot overcoat one-part paints. Their more aggressive

The existing mast finish has adhesion problems (flaking, blisters) and corrosion pitting that may require, at least in some areas, stripping the spar to bare metal and starting from scratch.

solvents turn the one-part substrate to a messy goo. A two-part paint with poor adhesion is also removed. If in doubt, it's best practice to perform the industry standard cross-hatch scratch and solvent resistance tests. (See "Coatings Tests" on page 14.) Previous coatings that fail either of these tests require removal by sanding with 80-grit discs or by media blasting (if available). Chemical strippers also exist and are commonly used in the aircraft industry where sanding dust is anathema.

In the case of this spar job, the problem areas, where corrosion had pitted the aluminum and blistered, the previous coatings were stripped down to bright metal but the remaining paint in good condition was simply prep-sanded using a dual-action air sander and 220-grit 5" (127mm) hooked discs.



Paint that is flaking or pitted is stripped to bare metal by sanding with 80 grit hook and loop 5" (127mm) discs on a dual-action air sander. Sound areas are thoroughly sanded with 220 grit.

Other spar finishes require different prep options. An anodized spar (silver, gold, black or clear) needs a thorough prep sand with 220 grit to break the hard anodized surface to allow paint adhesion; otherwise, it's treated the same as a painted spar in good condition.

A bare, never painted, never anodized, never sanded aluminum spar allows the use of a completely different "no sand" or "wet" prep and primer system. In that case, the spar is scrubbed with a special acid cleaner and then immediately rinsed with water and, before it dries again, wetted by an acid etching treatment. This acid etch remains on for a few minutes and, before it has any chance to dry, is rinsed off with water. The spar is blown

dry and, as soon as possible, a specialized zinc chromate-based epoxy primer is applied. Unfortunately, this is a very thin primer with no build or filling characteristics so, when overcoated without prep-sanding within 24 hours by the final glossy topcoat, any imperfections (scratches, dents) on the spar definitely show. These systems (the best known is Awlgrip Fast Re-coat System) is a money saver, provided the spar is new or in good condition and the shop can cope with the acid contaminated waste water.

Another effective short-cut system popular with some custom spar builders brightens up a bare aluminum spar and gives the look of clear anodizing without the expensive trip to an anodizing tank. The bare (or weathered, anodized) aluminum is hand-sanded to a bright mat finish with fine 320- or 400-grit sandpaper and then cleaned with solvent and coated with a clear two-part polyurethane. The lack of primer goes against "the rules" but the inevitable flakes and chips are certainly less visible than on an opaque paint finish.



Two coats of epoxy primer (medium build) are applied by pressure-pot spray gun. Note the loss of paint as overspray.

Step 4: Priming

Back to the job at hand. After prep-sanding, most systems recommend the use of a fast drying zinc chromate wash primer on any bare metal surfaces. This is a "zero-build" pre-primer for enhanced corrosion resistance and is normally overcoated the same day with two sprayed coats of primer.

Since US Paint's Awlgrip was the particular two-part polyurethane paint system used for this job, we applied Awlgrip 545, a medium-build gray epoxy primer recommended for use with Awlgrip high-gloss topcoats. The decision was made to prime

all the spar surfaces (bare or not) including the wishbone. The resulting uniform grey primer coat makes it much easier to see any imperfections and fill them prior to topcoat application.

Step 5: Filling Imperfections

Within 24 hours of the 545 primer application (i.e., within its overcoat window), surfaces receive a slightly thicker Awl-Quik brushing epoxy primer applied without reduction (no thinning) as a fine filler or sanding surfacer where needed. This compound is squeegeed with a putty knife into any pinholes or sanding marks that might

New Found Metals.com

OWNERS OF ALL THESE BOATS AND MORE HAVE CHOSEN NEW FOUND METALS' PORTS

Alberg	Corbin	Islander	S2	
Albin	Coronado	Island Freeport	Sabre	
Allied	CS	Island Packet	Sagitta	
Aloha	DeFever	Island Trader	Seafarer	
Banner	Dickerson	Jeanneau	Sea Sprite	
Bayfield	Dolphin	Kittiwake	Skookum	
Beneteau	Downeaster	Lancer	Soverel	
Bombay Clipper	Duffy	Lazy Jack	Spray	
Bristol	Easterly	Little Harbor	Southern Cross	
Brewer	Egg Harbor	MacGregor	Spencer	
Cabo Rico	Endeavour	Mariner	Swan	
C&C	Ericson	Mason	Swift	
Cal	Excalibur	Mayflower	Sunberg	
Callber	Fantasia	Morgan	Tartan	
Camper Nicholson	Freedom	Monterey Clipper	Tahiti Ketch	
Cape Dory	Flicka	Nancy's China	Tayana	
Cape George	Formosa	Nelson	Tenor	
Cartwright	Freeport	Newport	Union	
Cascade	Freya	Niagara	Vagabond	
Catalina	Fuji	Nova	Valiant	
C-Dory	Galaxy	O'Day	Vancouver	
Celestial	Grampian	Owen	Vector	
Challenger	Gulfstar	Pacific Seacraft	Voyager	
Cheoy Lee	Hans Christian	Pan Oceanic	Wells Ketch	
Chris-Craft	Heritage	Passport	Westerly	
Coaster	Hinckley	Pearson	Westail	
Columbia	Hood	Rawson	Whitby	
Com-Pac	Hunter	Rhodes	Yankee	
Contessa	Irwin	Roberts	Yorktown	

Come to our website to see what sizes will fit your boat.

Call (888) 437-5512 or Email: nfm@newfoundmetals.com



"Your full service, fully stocked canvas super store."

Matthew Hunt

**Build it
Repair it
SAVE \$\$\$!**

Use a Sailrite Ultrafeed Sewing Machine—

- Portable, Powerful, Robust
- Mechanical Walking Foot
- Built in Welting Tunnel
- Straight Stitch up to 6mm
- Zigzag Stitch up to 5mm
- Excellent Support



#102500 Ultrafeed LS-1 Straight Stitch



#102600 Ultrafeed LS-1 Straight / Zigzag Stitch

Sailrite®
(800) 348-2769
www.sailrite.com
sailrite@sailrite.com



Call for a **FREE** copy of our 2009 Catalog.

Churusco, IN (260) 693-2242
Annapolis, MD (410) 263-6732



With the help of some additional lighting, Hadcock uses a putty knife to squeegee a fine filler or sanding surfacer (in this case an epoxy brushing primer) into any minor surface defects, such as scratches and pinholes. This sort of attention to detail is what differentiates a high-quality paint job from one that is just okay.

show through the primer. Any epoxy filler with the right viscosity (think thin mayonnaise) works in this application but the Awl-Quik is guaranteed to work well with its stable mate primer 545.

Step 6: Final Sanding



Primers are gently sanded with 320 grit to prepare the surface for topcoat application.

After an overnight cure, the primer and surfacer are carefully sanded with 280 to 320 grit, the dust removed with com-

pressed air and a tack rag and the paint booth cleaned of any dust in preparation for spraying.

Step 7: Topcoating



Spars are a bit tricky to spray paint. The painter is forced to bend and twist wearing full protective gear while applying the paint in a perfectly even pattern above, below and both sides. Runs and sags are not allowed.

The two-part polyurethane topcoat is mixed and thinned with reducer to just the right viscosity. The paint booth air make-up unit is fired up, providing a temperature controlled flow of air through the booth, and spraying commences.

A minimum three coats of high-gloss topcoat are required. The booth temperature is maintained overnight at no less than 60F (15.5C) to ensure a proper cure and, if possible, the spars are left over the weekend before handling to allow the coating to gain additional scratch resistance.

Step 8: Hardware Reinstallation

The hardware is laid out with help from the pre-removal pictures and, due to the number of stripped, over-

Taking care not to let a tool slip and scratch the new high-gloss finish, hardware reinstallation begins, including drilling new holes for the sail track.

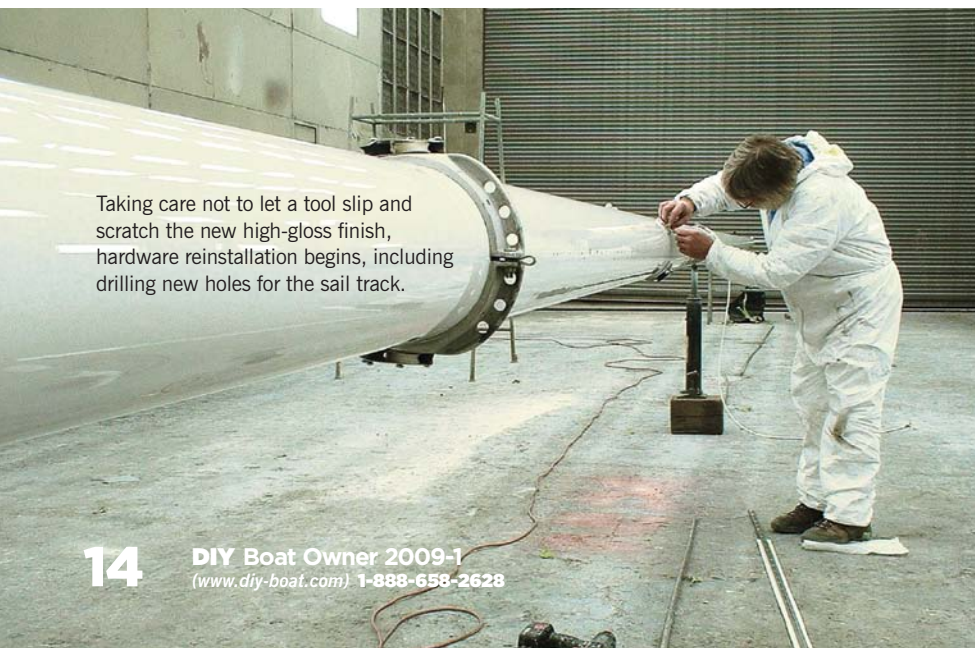

COATINGS TESTS

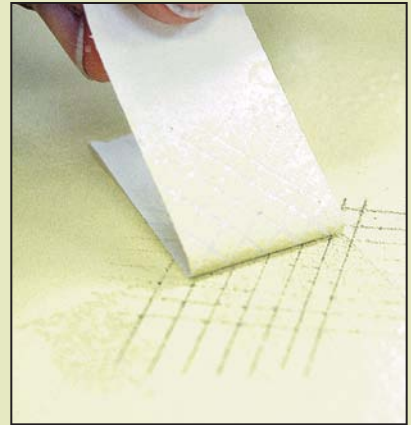

Jan Mundy

There are two tests to determine if the original spar finish can be overcoated with a two-part polyurethane paint.

First is the cross-hatch adhesion test. On a clean and degreased area of the surface to be painted, use a razor to scribe a 2" by 2" (50mm by 50mm) area with a checkerboard or cross-hatch pattern with cuts approx 1/4" (6mm) apart and deep enough to reach the substrate. Firmly apply a filament packaging tape over the test area. Do not use masking tape (as shown in the photo above). Yank the tape back abruptly with a motion parallel to the surface. Check the test area to see if any square of paint has come off. If so, the adhesion of the old coating is suspect and it should be stripped.

To perform the solvent resistance test, tape a cotton ball saturated with primer or topcoat reducer to the crosshatch area for at least 30 minutes and then remove the cotton ball. Check to see if the reducer has dissolved or softened the paint. If so, it's incompatible and should be stripped. Allow the test patch to dry for 15 minutes and repeat the cross-hatch test above to confirm adhesion when exposed to the reducers. As above, any square that pulls off indicates a removal of the previous coatings is necessary.

— NB

drilled and plugged mounting holes, the decision is made to drill a new set of holes for the mast track offset vertically by about 0.5" (12mm). This adds to the labor required but is the best solution.

Once the hardware is mounted, the mast is wheeled out for storage in a covered location and the wishbone padded and tied carefully under the boat on the cradle. No scratches so far and, hopefully, so it will stay until spring. 🍷

About the author: Nick Bailey has been honing his marine writing skills for over 33 years with his repair estimates and invoices.

CAUTION In the Boatyard

Recognize the hazards and minimize the risk of injury when working on a boat that is high and dry. Here's some advice from one DIYer who learned the "hard" way.

Story and photos by Paul Esterle

When DIYers head for the boatyard, project list and supplies all packed and ready to attack the job, few are likely to have boatyard safety requirements as priority one. We are usually focused on the task list and the promise of a new boating season or, at the other end of the season, we are preoccupied with what needs to be done before the fury of winter.

Maybe there are a few dust masks, some rubber gloves and other assorted "safety" items in your kit but is there a MSDS (material safety data sheet) for every container of paint, solvent, cleaning formulas and other consumables? What about the protective clothing, the GFCI (ground fault circuit interrupter) for the portable electric tools and how about those miles of orange extension cords? And that ladder, the one that you've been promising to ditch for a new, taller, sturdier model. I was as guilty as anyone. That is, until the day I fell off the boat. It was an early spring weekend, when few people were in the yard. I always extended the ladder well above deck level of my sailboat to give me something to

steady myself when stepping from the ladder to the deck or back. That last trip, I grabbed the top of the ladder to steady myself as I stepped from the deck to the ladder. I must have inadvertently pushed against the top of the ladder because the next thing I knew the bottom of the ladder kicked out.

There I was, with my right foot still on the deck of the boat while my left leg dangled through the rungs of the ladder. The only thing that saved me from a nasty fall to the gravel below was the fact that I had tied the ladder to a deck winch with a bungee. That kept the ladder from falling completely away from the boat and allowing me to drop to the ground.

After a few minutes, I was able to extricate myself and get back down the ladder. No permanent harm done but I did have some painful scrapes, sprains and bruises as well as a much better appreciation for good boatyard safety practices.

Safe Ladder Usage

Ladders are one of the most common pieces of equipment around the boatyard.



(top). The scene of the accident, a long way to fall. (inset) Bungee tied to a winch prevented the ladder from kicking completely out and dropping me to the ground.

Extension or step, they're everywhere. After my fall, I started paying attention to how they were being used, or rather, misused.

One of the most common errors is trying to use too short a ladder for the job. I've seen people balancing on the tops of step ladders trying to reach that last little spot to wax. Read and obey the sign on the ladder that tells you not to stand or sit on the top.

A common problem with extension ladders is that they are placed at too steep an angle against the boat. The best way of knowing whether you have the ladder resting against the boat at the optimum angle is to stand facing the ladder with your arms outstretched and your feet even with the base of the ladder. Your fingertips should just touch the ladder.

I like to extend the extension ladder well above the deck level of the boat I'm boarding. This allows me to climb the ladder and step off onto the deck while



(left) This extension ladder is set up too short and there is no secure handhold to make a safe transition from the ladder to the deck.



A better way to secure the ladder: two line-man's straps and a security cable.



To set the proper ladder angle, place toes at the base, finger tips touching the ladder.



A better setup: Ladder high for a secure handhold and tied off to a winch. The heavy keel block prevents the bottom of the ladder from kicking out.



A 12' (3.6m) stepladder with wooden handrail added. You can't see it but it's tied off to the toe rail.

still maintaining an upright posture with something to support myself. This practice also contributed to my fall.

Now, I have the ladder extended as before but I place a heavy keel blocking timber against the base of the ladder to keep it from kicking out. The other thing that minimized my injuries was the fact that I had tied the ladder to the boat at the deck level. I originally did this to keep the ladder from falling to one side or the other (or having someone borrow it for "a few minutes" while I am upside down in the bilge), leaving me stranded. In my case, it also kept the ladder from sliding out any farther from the boat.

I use a tall step ladder to get aboard one of my boats. I like the wide base of the ladder for better stability. Unfortunately, the top of the 12' (3.6m) step ladder only reached the deck level. Using this ladder as is would violate my "too short a ladder" advice. I added a sturdy wooden handrail to the top of the ladder to allow me a stable grip as I stepped aboard. I don't know if it is

OSHA approved but it has worked safely for me.

Safe Footing

When sanding the interior and deck of one of my boats, I try to keep things clean but dust and debris still accumulate on the deck and the cabin sole. This combination of debris, such as used sanding discs and the dust, make for a very slick surface. The dust acts as miniature ball bearings under the discs and you can easily slide.

Respiratory Protection

Sanding requires several things. First of all, the sanders need to be hooked to a good vacuum cleaner to help control the dust. Many marinas require this and may rent the equipment. Dust from sanding paint is extremely fine, so find a filter for your vacuum that is designed to trap those fine particles. Even so, there is usually a little dust floating around, so don a good respirator. I use a lot of epoxy when work-

ing on boats. The additives that are mixed with the epoxy to form various fillers or change the epoxy characteristics are usually very fine powders. Keep your mask on while mixing these.

Dust isn't the only reason for a decent respirator. Many of the chemicals we routinely use aboard also call for wearing a respirator. My respirator of choice is one of the 3M units with the two replaceable cartridges. Those cartridges are available in different grades, from protection against inhaling sanding dust to limiting your exposure to toxic and volatile organic compounds (VOCs).

Eye Protection

Hand in hand with proper tool use is the use of safety glasses or goggles. It doesn't take much of a paint chip or wire from a wire wheel in a drill to ruin your eyesight. Chemical splashes from paint, epoxy or the like are also a danger. If you use polyester resin, be especially careful with the



Proper set up for sanding: eye protection, respirator, bunny suit and a shop vac for dust.



Buy a decent respirator! The eye protection went on after the author finished photographing.



All the reason you need for proper eye protection. Those flapper wheels throw dust and debris as well as an occasional flap.



Solvents, such as acetone, are also hard on the hands and I routinely use gloves when working with these products. In some cases, you may need nitrile gloves or other types of gloves to provide adequate protection.

These are just a few of the safety precautions that ran through my mind as I was hanging over the side of the boat.

I've not mentioned proper precautions for working with electrical cords or power tools. This stuff can be dangerous and one of the most dangerous aspects is failing to use common sense and take precautions. Ask me, I know. 🧯

About the author: An inveterate DIYer, Paul Esterle is a boating writer and editor when he isn't working on his fleet of old boats.



(top) A close up of the sander/shop vac setup. This older model has several problems, it's very noisy and the hose doesn't lock in the canister. (bottom) A newer shop vac is worth the expense. It's quiet and the hose locks in the canister, keeping it from pulling out at the wrong time.

catalyst, it can be deadly to the eyes. I regularly use safety glasses for general work, then switch to safety goggles when flying particles are present. I use a full safety face shield when there is a chance of a splash hazard.

Hand Protection

Hand protection is also important. As I mentioned above, I use a lot of epoxy products for use on my boats. Many people can become sensitized to uncured epoxy and break out with a rash, swelling or respiratory problems when exposed. I use a variety of protective gloves to keep these chemicals away from my skin.

Playing in Another's Yard

By Pat Kearns

Can you take your car to the car dealership shop and work on it yourself? How about going into your favorite restaurant and cooking your own meal? The boatyard owner who opens his yard to a DIYer is doing the equivalent. He's letting you use his property to do the same kind of work that he gets paid to do on boats. That's a pretty good deal. Just be sure to hold up your end.

The yard owner has a huge investment property, buildings, tools and reputation. A boat owner, a non-professional, who comes in to work there on his/her boat is a potential liability to the business. A DIYer who makes a mess, causes a pollution hazard, gets hurt on his own boat or damages somebody else's is a hazard to the yard's reputation and could result in fines, a liability suit, increases in yard insurance premiums and more, which is why so many yards no longer permit DIYing at all and many have limited DIYers to dedicated (and remote) areas of the yard.

When working in the other guy's yard you need a clear understanding of what you can and cannot do in the yard. If the yard does not have a written policy, do your own due diligence and ask for the guidelines. If they are not forthcoming, make some rules for yourself so that the yard's failure to provide guidance doesn't backfire on you. Check out the rules for ladders, electrical equipment and cords, going up the mast, spray painting, sanding and grinding, particle blasting, bilge water discharge, handling and disposal of petroleum product wastes and hazardous materials, staying aboard when the boat is on the hard. It's important to note that many marinas and boatyards, nationwide in the U.S., are working hard to achieve "Clean Marina/Clean Boatyard" status and your cooperation is one key to claiming and keeping that designation.

Almost universally, boatyards that permit DIYers prohibit boat owners from borrowing yard equipment or tools, chatting up yard employees for tips and sometimes bringing in paid outside labor to assist you unless you allow the marina to contract it out. Other major "no-nos" include loud music, unleashed dogs, unsupervised children, unattended heaters, moving or adjusting boat stands and any repair activity that could affect other boats in the yard. Common sense should dictate that you don't dump your Porta-potti in the marina restroom toilet or use the restroom sinks to wash grimy, greasy or paint covered tools. Also, the yard dumpster is not the repository for old batteries, shrinkwrap, used oil or other hazardous waste that is routinely recycled.

To learn more about the codes and standards for boatyards and their activities, check out the websites for National Fire Protection Association Standard 303 (www.nfpa.org), ABYC TY-28 (www.abycinc.org), EPA (www.epa.gov), Occupational Health and Safety Administration (www.osha.gov) and Google "Clean Marina/Clean Boatyard" for state by state programs; or visit NOAA's Clean Marina site at <http://coastalmanagement.noaa.gov/marinas.html>. Also Google "boatyard regulations" and "do-it-yourself boatyards" and you'll find links to even more useful information.

Cool-headed and logical thinking in the heat of threatening conditions helps. We can all learn from this boater's methodical approach to a mysterious engine problem.

LOSING PRESSURE



Author points to the faulty oil pressure gauge.

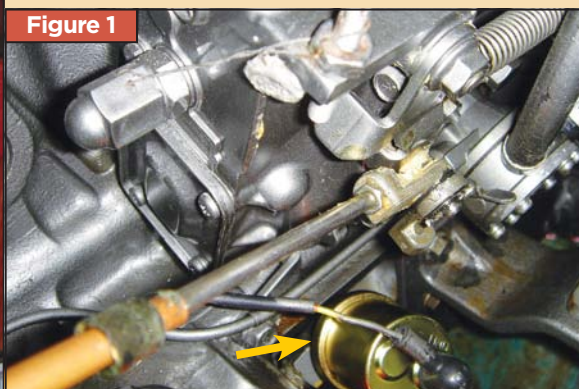

Figure 1

Oil pressure sensor on side of 4JH2E Yanmar.

Story and photos by Harry Hungate

We were just preparing to depart our anchorage in the Iluka River on the Queensland Coast of Northeastern Australia when the VHF radio crackled to life, warning of an earthquake in the Solomon Islands and a tsunami threat for Australia's East Coast. We had less than a half hour to cross the bar at the river's entrance and reach the safety of deeper water offshore but we felt that it was unwise to remain at anchor in shallow water. Mercifully, the tide was rising, allowing us to cross the bar safely. The timing was critical but we felt that we had no choice but to run.

Just as we were approaching the bar, I happened to glance down at the instrument panel, only to see the oil pressure gauge begin a slow descent to zero. My first thought was, "This cannot really be happening; first a tsunami warning and an onshore wind and soon no engine on a rocky lee shore." Struggling to avoid

panic, I listened for any unusual engine noises and carefully watched the coolant temperature gauge for any increase. Loss of engine oil pressure causes increased valve train noise, hopefully prior to engine seizure. Lubricating oil also assists in cooling the engine, so the engine coolant has to carry away additional heat. The engine continued to sound normal and the coolant temperature was constant. Then I remembered the low oil pressure warning alarm, a red light and buzzer. No alarm! I've got oil pressure. What a relief! It must be an oil pressure gauge failure.

We were into deep water offshore in a few minutes, so I shut the engine down and checked the oil level, just to make sure. It was fine. Soon the VHF radio announced that only a 4" (10cm) rise in sea level had been recorded and the tsunami warning was cancelled. Magically, the oil pressure gauge reading returned to normal when I restarted the engine.

However, by the next day, the gauge problem returned: no oil pressure at up to 1,200 rpm and normal oil pressure above 1,500 rpm.

Detective Work

At our next anchorage, I spent hours checking the wiring from the oil pressure sensor on the side of the engine all the way to the oil pressure gauge on the instrument panel. The wiring continuity was fine, the terminals were clean and tight, the wiring harness connectors were fully connected and corrosion-free. The engine shop manual gave no clues. At the next anchorage the mechanics in the marina engine shop suggested that the gauge itself was the likely culprit, as the oil pressure sensor almost never fails. Even at almost \$200 Australian for a new sensor, this was encouraging news but I could not find the problem. I had no way to check the gauge but I reasoned that, as

the gauge reading was repeatable (either zero or normal), perhaps it was okay after all and that the sensor was defective (**Figure 1**).

We finally arrived in Singapore in early October, and promptly flew back to the U.S. for our annual family visit and massive boat stuff buying adventure. I located a new oil pressure sensor for \$98 and hoped that I had not wasted my money.

Pressure Restored

Upon our return to Singapore, I measured the “at rest” resistance of the new sensor and found it to be 87 ohms. Our boat’s engine is a 1997 4JH2E Yanmar diesel engine and, while these measurements are specific to that particular engine

insurance against leaking oil and then wired. The engine was started and within a few seconds the oil pressure gauge rose to its normal reading of slightly over 4 kg/cm². No oil leaks were noted and the job was written up in the maintenance log-book.

The oil pressure gauge circuit is a series electric circuit (**Figure 3**). The gauge itself measures the small current flowing through the circuit. The sensor is a variable resistor, which changes resistance with changing oil pressure. Turning on the engine key switch applies 12-volts DC to the gauge. At zero oil pressure, the resistance of the sensor is high (87 ohms for the Yanmar sensor) and, as oil pressure increases, the

Sensors and gauges are matched, however. The resistance ranges are not standardized across all manufacturers so, when replacing a sensor or a gauge, be absolutely sure that the replacement is indeed identical to the original.

Discovery

I dismantled the old sensor to see what I could learn from it (**Figure 4**). The cause of failure was immediately obvious. After 10 years and 3,500 operating hours at constant oil pressure, the wiper contact had worn through the resistance winding at the point representing normal oil pressure. Normal oil pressure (3.5 to 4.5 kg/cm²) would decrease the sensor’s resistance to around 22 ohms. This explained why the

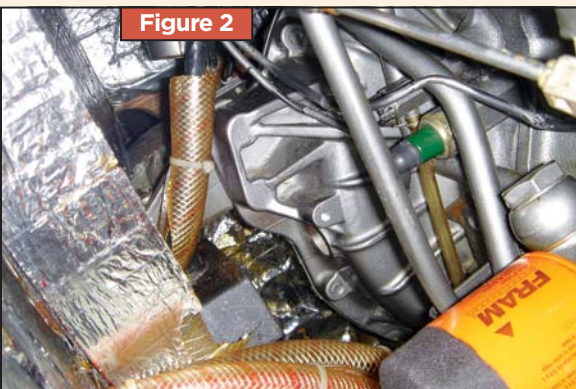

Figure 2

Check your engine manual so that you do not mistake the low oil pressure alarm switch, which is the smaller green object shown, for the oil pressure sensor.

model, the ideas presented here are quite generic and can be gainfully applied to all engines.

After disconnecting the wire from the old sensor, it read “open circuit” or infinite ohms, so now I was sure that I had found the problem. The hard part was removing the old sensor. Naturally, it was on the hard-to-get-to side of the engine, wedged in between the fuel lift pump and the oil filter. Be careful that you do not confuse the oil pressure gauge sensor with the low oil pressure alarm switch (**Figure 2**). The shop manual for your particular engine will have an illustration and approximate sizes of both the oil pressure sensor and the low oil pressure switch.

The sensor on our engine mounts is on a pulsation damper and I found that by rotating the damper a bit, better access was gained to the sensor. In no time, the new sensor was installed with a tiny bit of Loctite 567 sealant on the threads for

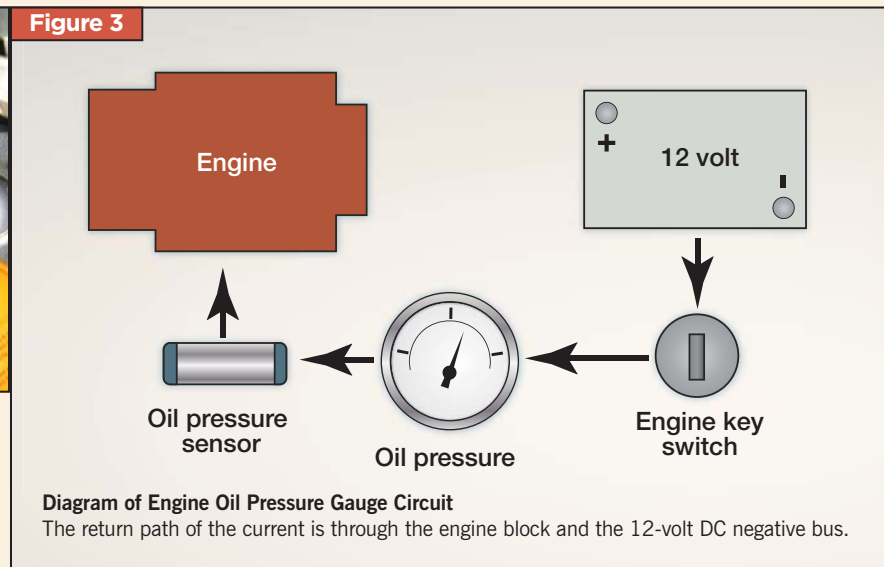

Figure 3

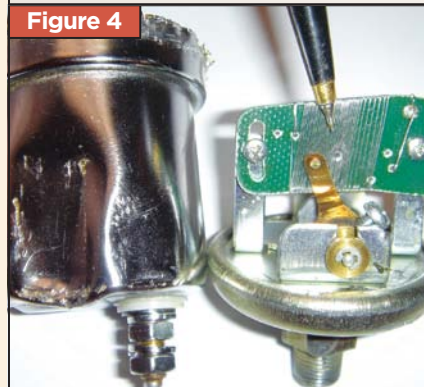

Figure 4
Cut open sensor showing wiper and broken resistance wire.

resistance decreases. This allows more current to flow through the circuit and the gauge translates the increased current as higher oil pressure. The circuit is extremely simple and reliable.

resistance reading at rest and up to 1,500 rpm was infinite or open circuit and the gauge read normal above 1,500 rpm.

There are a couple of lessons to be learned from this occurrence.

Electrical devices usually fail more often than mechanical things; oil pressure gauges are more likely to fail than oil pumps. Had our engine really lost oil pressure, the low oil pressure alarm would have given fair warning.

Engines are cheaper than boats. Had our engine really lost oil pressure, it would probably have run long enough to get us into the safety of deeper water or at least far enough away from the lee shore where we could have tacked to safety. ⚠

About the author: Harry Hungate and his wife Jane live aboard their Corbin 39 *Cormorant*. They departed Darwin, Australia in August 2007 and are currently cruising South East Asia.

Electrical Signals — Was Anyone Listening?

Things are not always as they seem when it comes to diagnosing electrical problems.

By Alan Donn

DC power systems are an enigma in the best of times and, when they malfunction, the clues are not always evident even to the most experienced technicians. Case in point is a 2003, 40' (12.1m) trawler of which I'm the professional captain. Certain electrical gremlins manifested themselves onboard over three seasons and culminated in a total loss of DC power during a trip from Connecticut to Florida. Fortunately, the total power loss occurred while moored safely alongside a dock in the St. Marys River, just off the Intracoastal Waterway on the Georgia/Florida border, but the meltdown could have just as easily occurred while traveling offshore enroute to Jacksonville, Florida. Onboard the boat were various retired submariners with knowledge of DC storage battery systems and other folks with long experience in small craft; a Cummins engine technician finally located the cause of the problem.

Twin Cummins 5.9L, supercharged diesel engines power this yacht. A DC charging alternator on each engine and a 9kW Westerbeke generator feed the three batteries, one for each engine, and an AC rectifier battery charger is installed in the system. Boat operation history includes numerous day trips or overnights in local New England waters with shorepower connected at the conclusion of each day, plus semi-annual delivery trips to and from Florida.

A small clue that something was amiss, obvious with 20/20 hindsight, was the fact that the AC battery charger always indicated a heavy charging current even though the engine alternators had run during the entire time while underway and should have topped up the batteries.

First Symptom

With the boat underway for the third day southbound on the Intracoastal Waterway (ICW), the Raymarine chartplotter display unit on the flying bridge shut down repeatedly and finally quit altogether. (Navigating

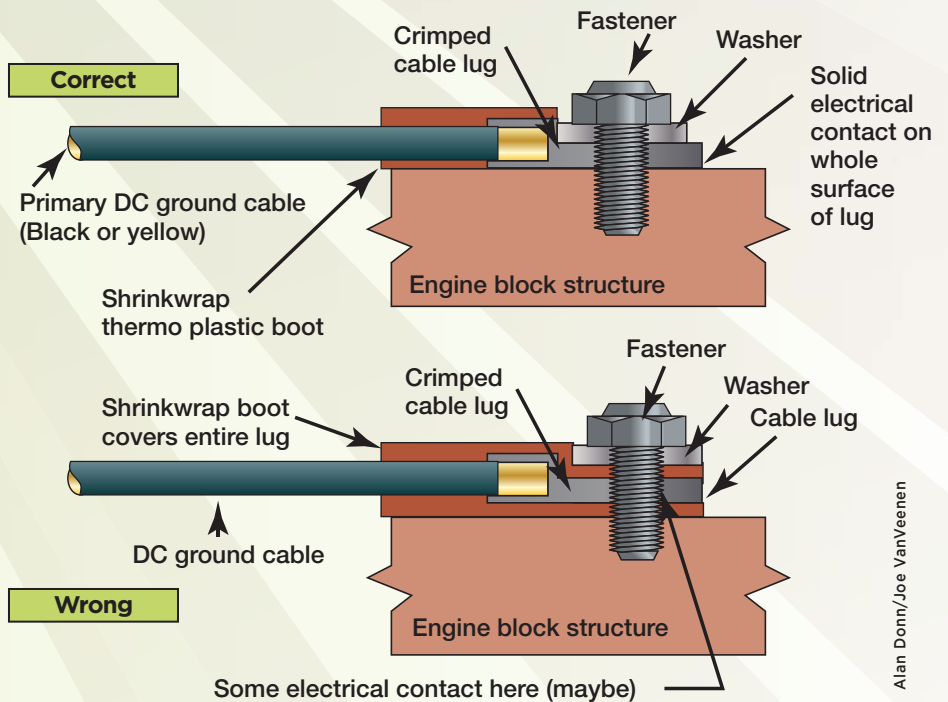

Alan Donn/Joe VanVeenen

down the Alligator River without electronic chart display or depth sounder information was fairly tense.)

We went alongside at Belhaven, North Carolina, and cleaned all connectors to the display unit and reconnected them. There was some evidence of moisture in the connectors and dielectric grease was applied as a sealant when reconnecting. The display unit behaved normally while underway the next day and thereafter all the way to Lighthouse Point, Florida. A key piece of information, one not recognized at the time, was that we were dockside on shorepower almost every night thereafter.

Second Symptom

On the return trip from Florida to Connecticut, the upper display unit was unreliable with the same general symptoms as before. Upon reaching homeport, we sent the display unit to Raymarine (still under warranty), where some water intrusion was discovered. The repaired and resealed unit was reinstalled and behaved normally for the rest of the season. All the symptoms up to this point indicated that

moisture in the display unit had been the source of the problem.

Third Symptom

On a short evening run, we tied up to a restaurant dock with no shorepower. Upon boarding for departure the engines failed to crank. The dinner guests went home by taxi and the crew turned to identifying the trouble. After cleaning and tightening all battery connections the genset started. With the genset providing AC power, the battery charger was put on line. After about two hours of charging, we were able to start the engines and we took the boat home. Loose connections. Problem fixed. No more problems.

Fourth Symptom

While on delivery again from New England to Florida, problems started with navigation lights going dim and then operating intermittently. A good whack would sometimes bring them back. While awaiting a weather window at Charleston, we dismantled all the navigation light fixtures. These flimsy fixtures had tiny spring-loaded contacts

that demanded exact aligning to make proper contact. They were also very sensitive to the assembly dimensions but had no provision to retain position once assembled. There were no suitable replacements available so we fixed the dimensions in place with Crazy Glue and hoped for the best. These indications pointed to a problem specific to the navigation light fixtures but not to any systemic problem with DC power. Shortly, we were underway again, offshore heading south.

Final Meltdown

At about 0200 and about 20 miles (32km) from the entrance to the St. Marys River, the navigation lights again started to dim and then, in rapid succession, both Raymarine display units shut down, the autopilot quit, the fathometer quit and the VHF radio died. All electronics were now down. The weather was cloudy, about 60% overcast, with choppy 4' to 6' (1.2m to 1.8m) seas. Fortunately, our system backups included a Garmin 276 mini chartplotter powered by batteries and two handheld VHF radios.

Cabin lighting was functional, as were the navigation lights, and the engines were running. Any electrical troubleshooting was precluded by the choppy weather and the necessity to steer the boat by hand. Hand steering with a GPS as the only directional reference is like trying to steer your car down the highway by looking out the back window. The GPS tells you where you were, not where you're going to be.

With only a tiny magnetic compass available, the stars were our best bet for a steering reference but the cloud cover made that problematic. Two more stressors included the fact that none of us onboard had traveled through the St Marys approaches before, by day or by night, and there was moderately heavy merchant traffic entering and exiting the channel. The mysterious electrical problem would have to wait. Adding to this, intermittent rain-squalls started as we approached the sea buoy, making it tough to use the paper charts.

Good preparation and good teamwork were key elements in our safe arrival. The backup GPS was already loaded with a full set of waypoints and a route had already been created for that leg of the trip. Up-to-date paper charts were also onboard. We lurched along, steering by the stars and checking the GPS from time to time for cross track error. Steering became much

easier as we sighted some fixed reference points on the beach and correctly identified all the approach navigation aids. Two crewmembers managed the chart and another pair managed the boat. Our handheld radios were adequate for safety communications with the merchant traffic and assisting tugs. We made the sea buoy in good order and by 0400 were docked at the first marina for some much needed rest. As a note to perfect hindsight, I'll mention that we did not connect to shorepower before turning in.

Fortuitous Final Failure

Our intention was to get underway in the morning and head south down the ICW to a marina with better facilities but upon awakening the absolute final gremlin reared its ugly head and put a stop to that plan. The Cummins diesels would not start, not even a "click" from the starter solenoids. Heading down to the engine room to begin tracing the primary battery cabling, we found no DC power anywhere, not even enough to light the engine gauge boards. We checked all the battery cabling, hand over hand, including the main ground connections, without finding any apparent problems. At this point we admitted defeat and called Cummins for help.

Diagnosis

Our instincts and submarine experience were basically sound. At first the Cummins tech was as baffled as we were but then he started checking continuity of the major ground cables. He discovered that there was no continuity in the primary ground cable that connected the engines to the DC return path. All cable lugs were physically tight. These were big heavy gauge cables with no apparent physical damage, but the multimeter wasn't lying. What could cause an open circuit here?

What he discovered when he disconnected the bolted connection was that the entire lug on the primary ground cable was covered by a shrinkwrap boot installed to seal the cable end when the boat was built. The only electrical contact was between the inside of the lug ring and the bolt. This tenuous contact was enough to enable the engines to start and run but was not enough to pass adequate charging current from the engine-driven alternators to the batteries. As the AC-powered charger had an independent ground path as long as the boat was on shorepower or genset, the batteries charged. While the

boat was on engine power alone, the batteries were discharged without any replenishment charge taking place. In addition, every time the heavy cranking load passed through this weak connection, arcing and sparking probably nibbled away a little more copper so that the connection grew steadily worse.

Hindsight

This boat's electronics problems were caused by low battery voltage. Since the display units were the most sensitive to low voltage, they were the first to show evidence of the problem but correct diagnosis was initially confused by the presence of moisture. The navigation light problem was also a clue but the physical problems with the fixtures again confused the diagnosis. With perfect hindsight, the big picture was obvious. When the boat was operated for any length of time on engines alone, the batteries discharged as neither engine-driven alternator was providing a charge. When the boat was put on an AC power source, either shorepower or genset, the battery charger would run and the batteries came right back up again.

I use the term "fortuitous" for the final failure that kept us from leaving the marina because the shaky ground connection almost surely would have failed shortly after we left the dock and been underway in the St. Marys River or the ICW. By preventing us from getting underway, the failure forced us to troubleshoot in depth to find the root cause before we proceeded. We had been lucky up to that point in that it did not fail totally until after we were tied safely dockside. There was just enough conductivity to sustain the engine fuel solenoids while we were underway. If the connection had arced through while we were in the approaches to St. Mary's or when we were too far offshore for handheld VHF communications, we would have been in serious trouble.

There are lots of lessons to be learned here about preparedness, back-ups and teamwork but it's also good to be lucky now and then. 🍀

About the author: Alan Donn operates Yacht Management Services, a powerboat and sailboat delivery and yacht management firm based in Groton, Connecticut. He served 20 years in the U.S. Navy submarine service and holds a master 1,600-ton, oceans license, is an IMO/USCG certified maritime instructor and an electronic navigation systems consulting engineer for the USCG R&D center.



UNDERWATER BLING

Adding underwater lights is a relatively simple improvement for your tender.

Story and photos by Roger Marshall

When guests come aboard your yacht, the first thing they usually see is the yacht's tender. As is often said, you only get one chance to make a first impression. Seeing your yacht tender floating in a sea of underwater light immediately creates the image that this is going to be a magical experience.

Tender-size underwater lights from Aqualuma (www.aqualuma.com) are not inexpensive, about \$700 per pair, but the installation is easy for a skilled DIYer. This installation was actually done on our RIB by my college-age son.

Installation Steps

Step 1: Preparation

Determine where you will install the lighting. In our case, we chose the Aqualuma Model 1 Series lights and these are installed about 3' to 5' (1m to 1.5m) apart just below the waterline. Set each light 2" to 4" (50mm to 100mm) below the waterline for best effect. Use a grease pencil to mark light placements then look inside the hull. Make sure the 4-3/4" (120mm) long lights fit inside the hull without hitting any structural members or puncturing a tank. Check, too, that there is sufficient space to fit the inner flange that measures 3-1/2" (88mm) in diameter. These preparations are extremely important. Getting it right now saves hours of heartache and possibly a sunken tender later.

Step 2: Drilling Holes

Drilling a 1-7/8" (48mm) hole for each light is the intimidating part. When you have drilled the holes, dry fit each light and mark the flange perimeter. Mask the



After drilling, check the fit before continuing.

outside border and then wipe carefully around each hole with a solvent-soaked rag to remove as much of the bottom paint as possible. It may be necessary to lightly sand the area to get down to bare fiberglass. The stripped area measures about 1/2" (12mm) around each hole. Next, sand around the holes to round off the cut edge and provide a slight recess for the caulking around the flange.

Step 3: Set the Lights

Lightly wipe the flange with solvent to remove any contaminants and then coat the back of the flange with Bostik 940 FS black caulking supplied with each light. Aqualuma recommends that you use only the provided Bostik sealant.



Set the lines in the lens to vertical when installing.

When setting the light, make sure the lines in the lens are vertical. These lines act as prisms to spread the light sideways. You'll need a helper inside the boat to put the internal nut/flange in place while you hold the exterior flange so that the lens stays vertical. Hand tighten the inner nut/flange. Do not use a wrench or spanner. Caulking will ooze out around the flange as you tighten the inner ring and that's ideal. Use the rounded end of an ice cream stick to scrape off excess caulking on the outside of the hull and create a finished edge.

Step 4: Wiring

Wiring the lights is easy. Simply mount the Aqualuma Series 1 control on a nearby bulkhead out of the range of any bilge water. Run the power line from the lights to a switch. Each light comes with its own connector so just plug the connectors into the control unit. Note that the lights are polarity sensitive so the red wire connects to the positive side of the switch and the black wire to the negative side. You'll need a 5-amp fuse for each light. If you need to install a dash switch, use a

waterproof switch. These lights draw 0.9 amps each.

Step Five: Light Up

Turn on the lights briefly to check that everything works properly and then launch the boat. Check for leaks. If you've done the job properly, there will be no leaks. Wait until dark and turn the lights on. Your tender now floats in its own sea of light and probably attracts any number of underwater denizens to delight your guests.

Maintenance

To maintain your Aqualuma lights, wipe the outer lens with a soft cloth at monthly intervals. If you need to get access to a light for any reason, haul the boat and work on the light from inside the boat or remove the light and go through the installation procedure again. Aqualuma says that there is no internal servicing required. ⚠️

About the author: Roger Marshall is the author of 12 books and is currently completing his latest book, *Fiberglass Repair Illustrated*.

The beach isn't in any catalog.

Neither is the cruise ship that will take you there.

WEST SYSTEM has been helping beach lovers build, restore, repair, patch and maintain their own cruise ships for nearly forty years. We have quite a reputation for it in fact. We did write the book on wood/epoxy boat construction.

For boat building and repair, reliable and easy-to-use WEST SYSTEM Epoxy is the world's leader. When they say marine epoxy, they're talking about WEST SYSTEM Epoxy.

And our expert technical advice, based on decades of hands-on building and repair experience, is just a toll-free call away.

Get your cruise ship ready to take you to your personal paradise. Find your nearest WEST SYSTEM dealer at www.westsystem.com.

Call 866-937-8797

Gougeon Brothers Inc., P. O. Box 908, Bay City, MI 48707



WEST SYSTEM
BRAND®

Safe Strong Reliable

Ignition TUNE-UP

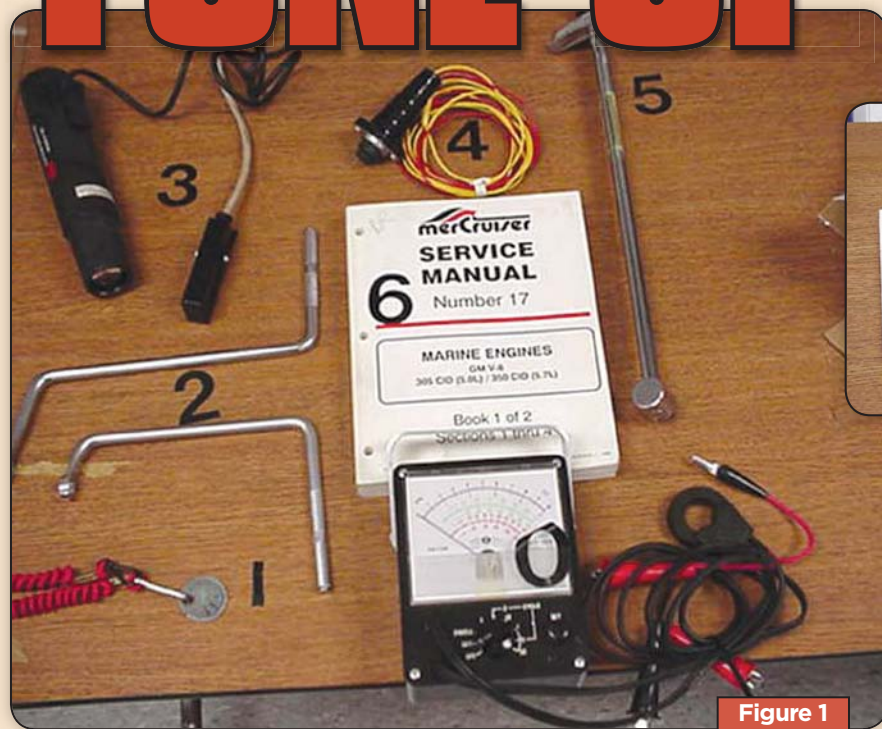

Figure 1

Tools Required:

- Engine service manual (6)
- Standard set of hand tools
- Torque wrench (5)
- Feeler gauge set
- Spark plug gapping tool (1)
- Tachometer (dwell meter) (0)
- Multimeter
- Timing light (3)
- Remote starter switch (4)
- Distributor wrench (2)
- 10" (25cm) piece of old fuel line (to install spark plugs)
- Spray lube (WD 40 or similar)
- Never-Seez lube



OEM Parts Required:

- Breaker points
- Condenser
- Cam wick (for lubricating the distributor cam so the point arm does not wear off)
- Distributor rotor
- Distributor cap
- Ignition wire set
- Spark plugs

Story and photos by Steve Auger

Most sterndrive and inboard engines manufactured in the '70s and '80s use an ignition system that utilizes a cam-driven breaker point set to control the voltage that is delivered to the distributor. This in turn, sends the voltage to the spark plug to create spark in the correct cylinder under combustion. This system relies upon several mechanical components, which must be in good working order for the engine to perform at maximum power and efficiency. If your engine does not run or run well and has not been serviced recently, an ignition tune-up is often the most logical place to start.

Before attempting any ignition system service or repairs you need to obtain a service manual for your engine and some specialized tools. **Figure 1** lists

the required tools and parts. This article is to be used on a functional engine in conjunction with your service manual and not as a stand alone tune-up guide.

Components

The four main components that make up a breaker point ignition system are the ballast resistor, the distributor, the ignition coil and spark plugs.

A ballast resistor is a device installed on the power wire that drops the system operating voltage from 14.5 volts output by the alternator down to 8 to 10 volts. This lower voltage greatly prolongs the life of the breaker point's electrical contact area.

The distributor consists of a cam mounted on a shaft that spins clock-

wise, a set of ignition breaker points, a condenser and a mechanical ignition timing advance. Mounted on the top of the distributor is a distributor cap and rotor that send the spark to the correct cylinder. The distributor cam is designed to open and close the breaker points as the distributor shaft spins. When the points are closed, there is no spark emitted from the high tension lead of the coil. The amount of time the points are closed is referred to as dwell and is measured in degrees of crankshaft rotation, e.g., 30 degrees of dwell. When the points open, spark emits from the coil. The amount of time the points are open is referred to as spark duration and is also measured in degrees of crankshaft rotation. As engine revolutions



Distributor shows rotor points and condenser mounted to breaker plate.



Using a distributor wrench to adjust base timing.

increase, the ignition event must occur sooner in order to ensure complete combustion in the cylinders. This is referred to as ignition timing advance and is controlled by a set of weights and springs located under the breaker point mounting plate in the distributor.

The ignition coil is the component that emits the high voltage that is routed to the correct cylinder by the distributor. The coil is usually mounted on the intake manifold close to the distributor. Coils do wear out and need replacing after 1,000 hours or 10 years to ensure proper ignition system performance.

The spark plug is installed in the cylinder head of the engine. The spark plug is designed to create spark yet disperse the heat associated with combustion. Spark plugs come in many different configurations. Always use the recommended spark plug with the correct thread length and proper heat range or engine damage could result. Always torque spark plugs with a torque wrench to ensure the plugs do not overheat. Refer to your service manual for torque specs.

To service spark plugs that are difficult to access, use a piece of fuel line with the spark plug shoved into one end. Just spin it in by hand. Never install spark plugs with tools or you may cross thread the spark plug. I dab a little Never-Seez on plug threads before re-installing.

Current Rules

Electricity will always take the path of least resistance. With a breaker point ignition, current from the battery is routed via the ignition switch, through the ballast resistor to the ignition coil positive terminal, through the coil and then out of the coil via the negative coil termi-

nal to battery ground through the closed breaker points, as this is the path of least resistance. The end result is no spark.

When the distributor cam opens the breaker points, the path of least resistance becomes an open or incomplete circuit that forces the current to exit the coil via the secondary circuit, through the coil high tension lead to the distributor, where the spark is routed to the correct cylinder. This gives a spark.

Tune-up Steps

Warning! This system can produce a voltage output of up to 17,000 volts at the high tension lead of the coil. This amount of voltage can cause seri-



Remote starter switch connected to starter solenoid.

ous injury or worse. Carefully read the instructions in your service manual before beginning service.

To begin, first verify the ignition switch is in the "off" position. Install one of the remote starter switch leads on the starter solenoid yellow/red connection and the other end to the battery positive or any other suitable battery power supply. Remove the

distributor cap and rotor. Leave the spark plug wires in the distributor cap and on the spark plugs. They will be changed later.

Step 1: Changing Points and Condenser

Being careful not to drop any screws, remove the breaker point plate that holds the points and condenser in the distributor. Remove the breaker points and condenser from the plate and install the new points and condenser. Leave the point screw snug; points will be adjusted later.



Removing the breaker plate.

Tighten the condenser screw securely. Be sure to lubricate the breaker point arm and install a new cam wick, if so equipped. With the breaker point plate removed you can now inspect the mechanical weights and springs that control the ignition timing advance. Verify that the weights move freely and that the springs are in good shape. These components can get rusty so give them a liberal application of silicone spray. Wipe up any excess silicone and install the breaker plate complete with the points and condenser you previously installed on the plate. Install the breaker plate mounting screws and tighten securely.

Step 2: Setting Point Dwell

Using the remote starter switch you previously connected, roll the engine over in short bursts until the high point on the distributor cam and the breaker point arm line up. Using the feeler gauge set the gap on the points at 0.020" as a starting point. This setting of 0.020" should produce a dwell of around 30 degrees.

To set the dwell accurately, hook up a dwell meter to ground and the coil

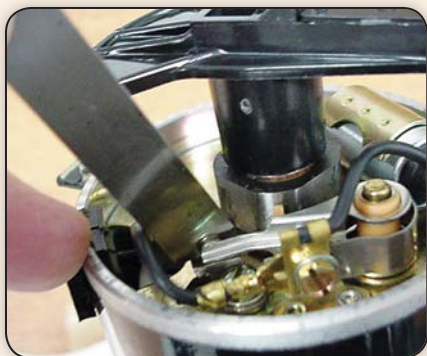

Setting point gap with a feeler gauge.

negative lead. “Zero out” or adjust the dwell meter to “set.” Reinstall the original cap and rotor. Supply cooling water to the engine and start the engine. Note the dwell. If it’s not to specification, reduce the point gap to increase dwell and increase the point gap to decrease the dwell until achieving your specification. Tighten the point retaining screw securely.

Remove the original cap and rotor and install the new rotor and distributor cap. When you set the base timing leave the dwell meter hooked up. If the dwell changes more than 3 degrees from idle (650 rpm) to mid range (3,000 rpm) the distributor bushings are worn out and the distributor needs replacing.

Step 3: Spark Plugs and Wires

Using the old distributor cap as a guide, replace the spark plug wires one at a time. Start with the wire closest to the coil and work your way around the distributor cap in a clockwise direction. Once you have replaced all plug wires, remove and replace the spark plugs, one at a time, being sure to reconnect each spark plug wire as you go so as not to mix up the wires in relation to the firing order of the engine.

Be sure to gap each plug to the specification in your service manual prior to reinstallation and torque each plug to specification.

Step 4: Checking Base Timing

With a water supply connected to the engine or, even better with the boat in the water, start the engine and warm up to operating temperature. At idle speed (650 rpm), hook up a timing light to the spark plug lead to cylinder number one. Check the ignition timing by pointing the timing light at the harmonic balancer of the engine. If the timing is correct, the



Checking base timing with a timing light.



Timing marks on a GM 350 CID engine.

timing light shows a scale on the harmonic balancer with a pointer on the engine timing cover. For example, GM 350 CID engine would have the pointer and the “#8” lined up, indicating the timing is set at 8 degrees before top dead center.

If the timing is not set correctly, loosen the distributor retaining bolt. Do not remove the bolt, just loosen it. With the engine idling, turn the distributor back and forth until the correct base timing is achieved. Once the correct based timing has been achieved, retighten the distributor hold down bolt and recheck the tim-

ing. Sometimes, it takes a couple of tries to get the timing right on the number.

That’s it for a breaker point ignition tune-up. Keeping the engine tuned up reduces fuel consumption and increases power. I always advise boat owners to change the engine oil immediately after a tune up, as a poorly tuned engine contaminates the oil with fuel much more quickly than a well-tuned engine. 🔥

About the author: Mercury Mer cruiser master technician and DIY’s engine technical advisor, Steve Auger, has more than 35 years experience in marine retail, manufacturing and training, mostly with Mercury Marine.

All that's Silver is not... STAINLESS

Stainless steels are a sum of their components and not all are created equal. Knowing what to select and how to properly install helps to eliminate the maintenance issues.

By Doug Cohen

Stainless steel is probably the most misunderstood metal used for fasteners encountered by the average DIYer.

If you have ever tried to cut or drill a stainless-steel bolt or screw, you know it's a great way to fry drill bits, wear out saw blades and frazzle your patience! As a result, you may think that stainless steel is very strong. Wrong?

Stainless steel is what metallurgists refer to as "tough" or not always strong. In fact, stainless steel fasteners are only about as strong as SAE Grade 2, a rating exceeded in strength by some alloys of aluminum and even some species of wood. [Ed: For a complete primer on the selection and proper installation of non-stainless-steel graded fasteners refer to DIY 2006-#3 issue.]

What's Stainless?

Stainless, originally called "rust-less," is an alloy of steel (very low carbon) with a chromium content of a minimum of 12%.

Although there are over 100 different alloys of stainless steel, divided into austenitic, ferritic and martensitic classes, most commercial fasteners are of two alloys: 304 (18-8) or 316. The designations refer to the alloy's content with 18-8 comprised of 18% chromium and 8% nickel. Type 316 has 16% to 18% chromium and 11% to 14% nickel, with the addition of between 2% and 3% of molybdenum, which increases corrosion resistance and strength. Most stainless-steel sheet metal or machine screws are made of type 410 stainless steel, although other alloys are sometimes utilized.

Originally, stainless-steel fasteners came with no head markings to distinguish them other than the familiar pair of lines at 90 degrees to each other on a type 304 (18-8) bolt head or the "316" marking on a type 316 bolt head.

Newer bolt marking methods are illustrated in **Figure 1**. Additionally, there is a requirement for a manufacturer's logo or trademark, registered with Industrial Fastener Institute, making the fasteners traceable and the manufacturer accountable for quality.

Put Into Practice

Don't make the mistake of replacing a graded fastener (Grade 5 or 8, or metric 8.8 or 10.9) with a stainless-steel one. If you do, the result will be a fastener failure, as stainless steel is nowhere near as strong as graded fasteners.

Using stainless-steel fasteners presents some issues not found regularly with graded, plated fasteners. First, stainless fasteners are not as smooth on the thread flanks, either on the bolt or the nut. This can result in galling and, if used with an impact drill or mechanical driver, causes cold welding of the threads. This prevents the proper tightening of the connection and makes disassembly impossible.

Since stainless steel is weaker than graded fasteners, you must be mindful of the installation torque used. For instance, a 3/8-16 Grade 5 fastener, clean and dry, is installed with 31 foot pounds of torque. The comparable bolt in 304 stainless is only installed to 19 foot pounds.

Many stainless-steel applications require protection from vibrational loosening, normally by using nylon insert hex nuts. Stainless-steel fasteners cannot be used with any type of all-metal locknut, as the cold-welding process discussed above occurs, resulting in the nut and bolt becoming impossible to disassemble.

Figure 1 - Head Markings

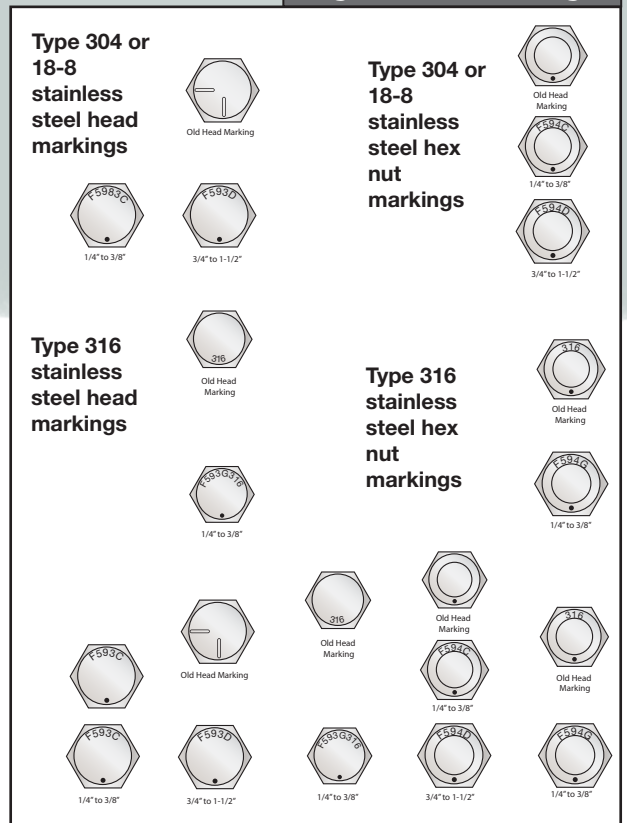

Hidden Trouble

Corrosion protection is a basic part of the stainless-steel chemistry, it's not a surface applied or plated process and, as such, it offers an interesting advantage over plated steel fasteners. In the presence of oxygen, the material "heals" itself if scratched, forming a film of chromium oxide on the surface. This film is invisible, thin, inert and is what creates the resistance to corrosion.

When deprived of oxygen, however, stainless steel is subject to crevice corrosion, eliminating the chromium oxide protective layer. This is why you need to be watchful of "hidden" potential failures, such as a sailboat's chainplates just below deck level or a fastener inserted through deck hardware. If water gets under the caulking and stagnates, it creates an oxygen poor environment, in which the stainless-steel fastener begins to corrode, eventually failing completely. 🔥

About the author: Owner of an industrial supply company and a marine surveyor, Doug Cohen and his wife, Fran, sail *DreamKetcher*, a 1973 Gulfstar 41' (12.4m) center-cockpit ketch on Lake Champlain in upstate New York.

SWINGING A COMPASS

A GPS solves the mysteries of compass calibration, making it easier for you to swing your own compass.



Figure 1
Typical compass adjusters.



Michael Irving/Danforth Compass

By John Meskauskas

On a recent cruise, my computer navigation system stopped working. I had paper charts but realized that my compass was way off, around 15 degrees or more. My first thought was to put the boat on autopilot while I figured everything out but that wouldn't work properly either. Fortunately, the GPS was working and I used the GPS magnetic course display to steer by so there was no immediate problem. Three major systems were now inaccurate or inoperative: the autopilot, compass and navigation system.

The autopilot error is easiest to explain. When my older autopilot is initially turned on, its fluxgate compass setting must be within 10 degrees of the magnetic course or it cannot converge on a proper course. I had prepared a deviation table for the autopilot compass relative to the main compass but this was now useless. I needed to go back to basics, to "swing" (adjust or compensate) the compass to minimize deviation through adjustments, to gather deviation data of differences that can-

not be adjusted away and to prepare a deviation table of those values at various headings.

My compass had been accurate to within 2 degrees (the generally accepted standard) for years now. So what caused this error? Sources of magnetic influence on the compass include permanent magnets such as speakers, iron objects such as the engine and magnetic fields from electrical equipment. Initial suspects were a new DSC VHF radio with its associated loudhailer, both within 4' (1.2m) of the compass. These certainly had some influence but, ultimately, I discovered that the compensating magnets had gotten wet and rusted away. Replacing them was the first step in swinging the compass.

A compass reading is the result of variation (earth geographic influences) and deviation (local vessel influences). The earth's magnetic poles are not in the same places as the geographic poles, resulting in variation, which is eastward on the West Coast of North America and westward on the East Coast. Variation

FINE TUNING

The internal compensators provided in most compasses compensate to a maximum of approximately 15 degrees. If your error is greater than that, you will need external magnets. I cut up a refrigerator magnet into narrow strips and found that one strip had about a 2-degree effect but that the effects were cumulative when I stacked strips onto each other.

If your adjustments don't yield an accurate result, you'll need to get some professional help. You will find compass adjusters under the "service" category in the major compass manufacturers' websites.

Here's a tip from Will Keene of Edson International: Steering pedestal hardware is demagnetized at the factory but can become re-magnetized (the chain, for example) if you use a magnet to test. Use a compass card, such as on your hand bearing compass, to test for magnetism.

— JM

increases the further north you go. When you set your GPS to display a magnetic heading, it invokes an algorithm that calculates the variation and adjusts the displayed magnetic heading based on your position.

A compass with no deviation error points toward magnetic north. However, when something changes in the magnetic influences near the compass, such as adding or removing equipment, electrical currents, leaving a wrench in a nearby locker, the net influence on the compass is deviation.

Before the wide use of GPS, swinging the compass was a black art. The first time I had it done, a gentleman came aboard looking like he had just stepped off a Navy ship, carrying a pelorus (a device with a compass-like card with rotatable pointing and sighting vanes used to take bearings) and a table of hand-written cryptic figures. He had me run courses aiming at conspicuous objects on shore that he picked after consulting his equipment and table. He adjusted the compass on one heading and then again on the opposite course and so forth through what turned out to be north/south and then east/west adjustments. After about an hour of this, the compass was nearly dead on. With GPS, the navigational mysteries are solved and it's much easier for you to swing your own compass.

TABLE 1 - COMPASS ADJUSTMENT RECORD

If this GPS course (magnetic) is:	The compass heading is:	And the initial deviation is:	On this pass, compass was adjusted to: Heading (deviation)
360 (0)	345	-15	352 (-8)
180	170	-10	175 (-5)
360	353	-7	357 (-3)
180	175	-5	178 (-2)
090	095	+5	092 (+2)
270	274	+4	272 (+2)

TABLE 2 DEVIATION TABLE

Magnetic course +/- Deviation = Course to steer
 Example: 45 + 1 = 46

Magnetic (GPS) Course	Compass Heading = Course to steer	Deviation
360 (000)	358	-2
010	009	-1
020	019	-1
030	030	0
040	041	+1
050	051	+1
060	062	+2
070	073	+3

Getting Ready to Swing

The three basic items you need are appropriate waters to do this, with the supplies and tools on hand, along with one or two helpers. To get an accurate GPS heading (unlike the compass), the boat needs to be moving. The GPS heading displayed at any given time is really a weighted average of (very) recent heading data. For that reason, when swinging a compass, steer as straight a course as possible and, after making a course adjustment, wait for a second or two until the course readout and the compass settle on their readings. Typically, you select a cove or bay where you can run very precise courses toward the north, south, east, west (plus or minus 10 degrees) for 10 to 30 seconds.

Before departing, become familiar with the methods of adjusting your compass and have the required equipment: a non-magnetic screwdriver for compasses with internal adjusting weights and adjusting magnets for exter-

nally adjusted compasses. The adjustments shown in **Figure 2** are typical. If you don't expect to have marks or objects to sail all the required legs, bring along a marker buoy with an anchor and line. Prepare and print a table to collect the data similar to **Table 1**.

Make sure your GPS is set to indicate magnetic north and turn on accuracy improving features such as WAAS. Before you leave the dock, check that your compass lubber lines are parallel with the centerline of the boat. This is easy to do if the compass is on the centerline. Mine is offset. I establish the boat centerline with fishing line between the masts to measure the offset distance from the centerline to the compass. A second centerline segment is set up between the mainmast and the forestay. Transferring the compass offset distance to an object visible from the helm, such as a lifeline, establishes a line parallel to the centerline to use to check the lubber lines.

TIP: WEIGHING LUBBER LINES

Lubber lines are the vertical posts on opposite sides of the compass that you use as references to read the compass card. The thickness of lubber lines is often 1 degree.

Swinging the compass

Use the GPS to set a general direction, then select an object on shore or a charted mark to steer toward. The helmsman steers toward the selected object while a helper resets the adjustment screws on the compass (**Figure 1**). Do this either in waters that have no current tide or are at slack (current) tide.

When we reached our chosen waterway, we did the north/south adjustments first. We picked a physical feature on land or a mark that was +/- 10 degrees of north to steer toward. When the GPS reading and course were steady, half the error was adjusted away using the north/south compensator. I made very small adjustments and gave the compass 2 to 3 seconds to respond. Next, I recorded the data using the format in **Table 1**.

To change onto a reciprocal course, we would do a Williamson Turn (**Figure 2**). Without changing the throttle, steer hard right (or left) until your course has changed 60 degrees, then steer the opposite until headed on a reciprocal of the previous course. The Williamson Turn was developed for man-overboard rescues; it puts you onto a reciprocal course on the same track. We then did our southerly compensation, adjusting away half the error.

We ran two sets of north/south adjustments and were mostly within 2 degrees of the GPS course after the last adjustment. We then repeated the series east/west, adjusting the east/west compensators.

The final step was to develop a deviation table. We sailed a series of courses 10 degrees apart, using the GPS,

RESOURCES:

Chapman Piloting & Seamanship
 Edson International; www.edsonintl.com
 Ritchie Navigation; www.ritchienavigation.com
 Danforth; www.danforthcompass.com

ADDITIONAL READING

The article titled, "Compass Points," originally published in DIY 2001-#2 issue, is now available on DIY's "Making the Electronics Connection" CD-ROM. In this article, a professional compass adjuster pilots you on a course of compass selection, installation, calibration and adjustment, including readability, compass performance and care, and how to avoid magnetic compass errors.

and noted what the compass headings were. After making a huge circle we were finished, leaving the deviation calculations for later. See **Table 2** for an example.

Commonly, deviation is noted as east or west. To calculate the course, you then apply the rule: to the magnetic heading, add west, subtract east. I prefer to eliminate this intermediate step and just put the sign in the table. When we do our chart work, we apply the chart variation information to reach a magnetic heading. On the water, apply

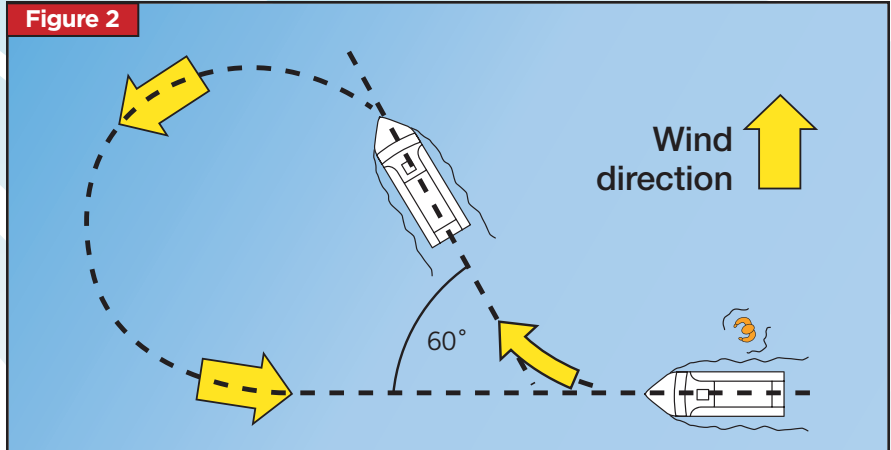

The Williamson Turn is a man-overboard vessel maneuver used to return a vessel to a starting position.

the deviation table value to find the course to steer. For example, in Table 2, if we wanted to steer 010 degrees magnetic, we would apply a deviation of -001 degrees and steer a compass course of 009 degrees.

Doing this added a level of precision to our navigation, connected us with generations of sailors who only had the compass to steer by and we practiced

a key component of our man-overboard drills—a good day on the water. We left the task of verifying our autopilot deviation table for another day. 🚤

About the author: Captain John Meskauskas is an offshore delivery skipper based in Wilmington, North Carolina and is experienced in the operation and maintenance of power and sailboats up to 50 tons.

Transport Canada/Joe VanVeenen

The Bronze Age IS DEAD

"The most common cause of dockside sinkings were found to be the result of deteriorated or corroded fittings such as intakes, seacock and drains below the waterline"
Boat U.S. NEWS 12/06/07

DON'T TAKE A CHANCE ON YOUR BOAT SINKING!
Make sure you have state-of-the-art, non corrosive Marelon® Precision molded plumbing systems for use **above** and **below** the **waterline**.

• COMPLETE FREEDOM FROM CORROSION • U.L. APPROVED • A.B.Y.C. COMPLIANT

FORESPAR
MARELON®

Forespar
22322 Gilberto
Rancho Santa Margarita CA. 92688
Tel: 949 858-8820 Fax 949 858-0505
E-Mail: sales@forespars.com

"Rub It On Until It Shines!"

Re-Structure Marine Polish

- No more waxing your boat every 6 months! Re-Structure Marine Polish is a penetrating polish – not a surface wax.
- No more machine buffing that removes your gel coat or paint finish.
- Polish your boat easily by hand. Will protect for up to three years.
- Can also be applied to your boat's interior and exterior.
- Re-Structure Marine Polish is **Nanotechnology produced, water-based, "zero petroleum" non-solvent, VOC compliant, environmentally safe** and contains **no abrasives**.

Put Re-Structure Marine Polish to work for you today!

RE-STRUCTURE MARINE PRODUCTS
(310) 639-7069
re-structuremarine.com

2008 N.M.M.A. INNOVATION AWARDS WINNER

Zen of Crew

COMMUNICATION

Close-quarters maneuvering requires synchronizing the crew and helmsperson. Hands-free, two-way communication devices are a great way to communicate without the theatrics.

Story and photos by Garrett Lambert

It's probably a truism that casual boaters would cruise more often if docking and anchoring were less stressful. Add wind and current to the confined spaces in marinas and you have plenty of opportunity to hit something expensive and wound your pride in the process. The usual solution is to station a crew member where he/she can add another pair of eyes to see what the helmsperson cannot. Unfortunately, this arrangement usually involved some shouting and tense moments can escalate communication to more intense levels.

Crowded anchorages with poor holding can be not only frustrating but also create embarrassing situations. No one likes having to make repeated attempts to set the hook in front of crews who have already settled in and are watching the new arrival. We've all observed couples testing marriages while providing entertainment to nearby audiences. It's all about coordinating dockside boat movement or anchor

handling and, while I know couples who use hand signals effectively, my wife and I much prefer talking to one another.

Past experience on our earlier aft cabin trawler taught us that two-way radios with headsets were better than high volume vocal chords alone. We also learned that radios must be full-duplex, meaning they use two frequencies simultaneously to enable conversations just like on a telephone. An extensive search over the past year turned up only three headset options that I deem suitable for boat use. They are reviewed below in order of price, highest first.

For the Pros

The Eartec TD 900 Cyber package (www.eartec.com) is a pair of professional quality, single purpose belt radios and headsets for \$300. Founded almost 50 years ago, Eartec has an array of core products that it packages in differ-

ent configurations to meet specific recreational and communications requirements. The TD 902 for mariners had its genesis in the Porta-phone communications systems used by football coaches throughout the U.S.

The kit comes in a foam-lined hard case and includes a pair of belt-clip TD 900 receiver/transmitters, a pair of battery chargers and a pair of ultra-lightweight headsets with boom mikes. The headsets are featherweight, comfortable and secure and have a single speaker for the left ear and a pad for the right temple. Last summer I watched my cell phone go over the side when its case was neatly lifted off my belt by the handrail as I was descending from the flying bridge. The TD 900 belt units appear equally vulnerable, so adding tethers to the slip-over clips would be prudent insurance.

Although the units appear to be physically identical they are labeled "Master" and "Remote." Buying extra remotes can expand the TD 900 network to include more crew. On the top of each radio are two push buttons, an on/off/volume rotary switch, plus three LEDs labeled "A," "B" and "Batt." Operation is straightfor-



(right) Eartec TD 900 kit. (left) Smaller loop on the headset sits over the ears with the larger loop at the back of the neck and a shirt clip keeps the wire out of the way.



Boaters will particularly appreciate the value of the Chargepod in eliminating wire tangles and lots of brand-specific chargers.

ward after charging the batteries. Turn them on and select the same channel on both, "A" or "B" so that both LEDs show green. Engage the talk button on both. The channel LED turns red to warn if only one unit is on "Talk." With the headsets plugged in, conversation is now enabled without any need to touch the radios again other than to adjust the volume and turn them off.

These radios operate in the 900 MHz spectrum that portable home telephones used a decade ago. As government allocated and opened new channels to short range public communications, phone companies moved up to the higher frequencies and abandoned the 900 band. As a consequence, the Eartecs have little competition for clear air. However, if for any reason there is a problem that switching channels fails to counter, the backs of the cases can be opened and dip switches changed to reset the units to any of 40 frequencies. The procedure is clearly illustrated in the eight-page user's manual.

As one would expect, conversation is crystal clear without interference of any kind. Range is about 100 yards and power comes from built-in batteries. This is a professional system.



(Top left and above) The Dragon V2 system comes as a kit that contains an earpiece, AC and DC chargers that connect via a USB cord, a manual, a connection cord to a Chargepod, an additional rubber ear bud and a soft zippered pouch to keep it all together.

Bluetooth Cool

When Callpod (www.callpod.com) introduced the first Dragon earpiece, technical problems and poor sound quality turned eager anticipation into disappointment. To its credit, Callpod responded quickly and launched the much-improved V2 last September so be careful to buy only the newer V2 model and not the original.

The Dragon V2 is a Bluetooth cell phone earpiece. A pair of V2s can also communicate directly with each other in full duplex mode with a line-of-sight range of more than 300' (91.4m). No cell phones required. A V2 kit lists for \$120 each.

The earpiece design provides plenty of adjustment to ensure comfortable in-ear fit. It swivels and slides on the wraparound frame's post and can be adjusted for angle because the little button through which the post slides also rotates. Rotating the earpiece 180 degrees around the button allows usage on the left ear but also reverses the direction of the volume control. Once a good fit is achieved, the V2 is quite secure. It took half a dozen fast, side-to-side headshakes to dislodge it but I would be very careful when leaning over the rail. A simple sweat band provides added insurance.

The Dragon charges quickly and battery time is five to eight hours. When first plugged in, a tiny red LED flashes until the unit is fully charged and then turns itself off. Connecting to another Dragon and/or a Bluetooth cell phone is simple and a tiny flashing blue LED signals the way. The device's memory enables pairing up to eight different devices.

We tested the dragons on our 40' (12.1m) pilothouse trawler. The sound throughout the boat was telephone quality

with no hum, hiss or static even with the engine and all electronics running. Ditto on the street in line of sight at well more than 200' (61m). If there is anything negative to be said, it's that in such a small package, the two controls are necessarily also very small and each is multi-functional. Persons not used to similar devices will need a bit of practice before it all becomes automatic.

The V2s are part of a larger system whose literal centerpiece is the Chargepod, a simple but very useful \$50 gadget whose six USB ports can charge as many as six different peripheral devices simultaneously from either 110-volts AC or 12-volts DC. Connectors are packaged with the Dragon and the website lists connectors for about 60 different cellphones and various music and other devices at a cost of \$10 each. For a couple with Bluetooth cellphones, choosing V2s for onboard comms is a no-brainer but they also attract anyone who values "cool."

Rebranding an Original

The last option is the Mariner 500 Headset Communicator package available at www.cruisingsolutions.com for \$60 plus the cost of a couple of 9-volt batteries. It consists of two headsets packaged in a soft, padded, zippered case with a hand strap. TechLink, a Taiwanese company, originally branded them Aviator 500 and supplied North American markets as a toy about 10 years ago. Boating couples were soon snapping them up and we were happily among them. Unhappily, when we sold our previous boat, one of the conditions of sale was that our valued headsets remain aboard.

I immediately went looking for another set but electronic toys have short shelf



Mariner 500: (Top) Each headset is completely self-contained. The left ear-piece hosts a speaker. (Middle) Removing one screw in the right earpiece opens a molded receptacle for a standard 9-volt battery. (bottom) A simple three-position slide switch offers the choice of Hi/Lo/Off.

lives and they had already disappeared from the market. While other full-duplex toy radios have since appeared, none was designed as well or with a headset and almost all have generated complaints about sound quality. Cruising Solutions resurrected and rebranded the originals, which have TechLink's name on them, and added the case.

As the photos indicate, the tall antenna and microphone boom are flexible but stiff enough to be positioned as required. The length of the antenna suggests they operate on a relatively low frequency, probably the reason external electrical/electronic



Hands-free Cobra FRS package that cost the author about \$80 and includes compact earsets with short boom mikes and a well-designed stand/charger.

sources can produce either a low-level background hum or more often, a hiss similar to the ambient noise on a passenger aircraft. However, neither hampers clear conversation even when speaking softly more than a couple of hundred feet apart. Some friends who have a pair complained to us about the hiss but, when I immediately offered to buy them, the offer was promptly refused.

The combination of convenience and simplicity cannot be over-stressed. You simply flick the switch and put them on. Range is hundreds of yards and battery life is remarkably good. Will they stand up? They were originally made for use by active children and we had no problems whatsoever during two years of adult use.

FRS RADIO

Lastly, we give a quick look at the ubiquitous Family Radio Service (FRS) and General Mobile Radio Service (GMRS) radios. Because many boaters already have a set onboard, (more than 100 million have been sold) I've included them in this review to demonstrate why these simplex (single channel) radios are inappropriate.

These are simplex radios, i.e. they use a single frequency that does double duty for transmitting and receiving so only one person can transmit or speak at a time. That sounds like it should be okay for our purposes but it isn't. Managing conversations is done manually, much like a VHF radio. After switching on, both units are set to the same channel (20 are available). In addition to the complicated suite of controls on the handsets, the ear pieces

have a small push-button on the wire clip similar to those on cell phone earbuds. However, the similarity ends there, because FRS conversations require push-and-hold to talk and release to listen. The problem becomes obvious immediately. When two hands are busy with the wheel, throttle(s), shifter(s) and possibly a thruster joystick, there's nothing left to manage the FRS radio. Ditto if the deck crew has an anchor rode or boathook and docklines in hand.

Some FRS radios, offer a hands-free mode known as vox, the Latin word for voice. When this setting is selected, the radio automatically switches to "transmit" when it senses a voice and then back to "receive" when the voice is no longer speaking. Unfortunately, there are lags in switching back and forth because the radio requires a moment or two to react to sound or silence, so the first spoken syllables are always lost. Operators can overcome this by starting each transmission with a phrase such as "talk, talk, talk," but this requires real discipline when urgency is priority one.

Simplex units simply cannot handle two people trying to speak simultaneously, a situation that inevitably arises during moments of stress. On the other hand, these radios are well suited for communicating between ship and tender, ship and shore for which VHF radio use is forbidden and during shore visits when we go our separate ways such as at large outdoor markets. Range is generally excellent.

Conclusion

Given the remarkably different technologies, designs and pricing, it's surprising that the TD 900, Dragon V2 and Mariner 500 each offer excellent value for the money. They all do the required tasks well and, which one to choose depends only on how a buyer balances cost, convenience and "coolness" factor.

Using any pair of these radios, we no longer raise our voices above genteel tones and it's far easier to maintain a Zen state in even the tightest circumstances. Best of all, if either of us does happen to lose it, no one else will know. 🍷

About the author: After three decades cruising the world as a diplomat, Garrett Lambert now cruises the Pacific Northwest where navigation and weather challenges play nicely into his interest in technological innovations.

TOP 20 DIY WEB SITES

Cast off on a keyboard cruise and enter the land of virtual DIYing and explore how to let your fingers do the walking in a cyber-toolbox.

By Pat Kearns

Ask DIYers about tools and you'll get an earful about their collection, where they found each item, how they use it, how cheap (or expensive) it was and every other rationale for coveting it, seeking it out, buying it, using it and bragging about it. Indeed, every new project is an easily rationalized excuse for a trip to your favorite tool vendor. When I worked in a boatyard, the arrival of the Snap-On truck was greeted with slaving pleasure and open wallets, as the yard crew climbed aboard for a trip to tool-lover's heaven.

DIYers are, by nature, gearheads. Every job has a point during which we assess what "tools" we need to approach the work. Some of them are steel and wood; some are paper; some are virtual and these tools are only a keyboard stroke away.

The computer keyboard is a powerful tool when it comes to unlocking the vast Internet resource of information that is fast and easy to get and mostly free. The keyboard's not exactly toolkit size unless you have a Blackberry or its equivalent, which will get you the whole Web in a pocket-sized edition.

What follows are some of my personal favorite sites and, like in cruising aboard, they are places I return to again and again.

www.Google.com

If you Google "boats," you'll get over 115 million hits. Pick one and it'll point you to links to others. Those links are like waypoints on the Web cruise. Search on any other boat/boating related word and the results will unfold. There are layers and layers of links that will take you to some unexpected "finds."

www.boatus.com

Start here for a truly incredible voyage into a land of virtually unlimited links to everything boating. The official website of BoatU.S. has a "News Room" for links to consumer affairs, U.S. Coast Guard updates, marine weather with interactive features observation features and automatic hurricane season updates, free copies of *BoatU.S. Magazine*, as well as *Seaworthy*, the damage avoidance magazine. Click on "Boat Buying" for boat reviews and a free boat value check. Click on "Resources and References" to access the "Boat Tech Library," "Ask the Experts" and articles from past issues of *DIY Boat Owner* magazine.



Hands-on product tests can be found under the BoatU.S. Foundation section and in the Consumer Affairs message board you can scan questions and answers on just about any boat or gear problem. The cost to access everything on the site is \$0, except that the area is dedicated to "members only." Join BoatU.S. for less than \$20 a year and get the full course meal anytime you like.

www.boatdiesel.com

There's no other site that can beat this one for diesel engine data. Some of it is available free but, for a \$20 annual subscription fee, you get the

benefit of being able to access an amazing collection of engine specifications, including transmissions and generators. There are calculators for prop and shaft sizes and horsepower requirements. There are also two of the best sections I've found on troubleshooting and service requirements for marine diesel engines. This site is number one for engine drawings of physical detail.

www.fiberglassclassics.com

Here you'll find information on old fiberglass boats, going back to the '50s and '60s. All brochures, pictures and information are free. It's a trip back for a visit to the pioneers in production fiberglass boatbuilding.

www.moyermarine.com

Moyer Marine is the leading provider of parts and services for the Universal Atomic 4 engine. Here you'll find completely rebuilt engines and hard-to-find remanufactured and aftermarket parts. Visit the "community forum" to shoot the breeze with other Atomic 4 enthusiasts, ask questions and share experience.

www.boemarine.com

Formerly byownerelectronics.com, this site features a "Buyer's Guide" that covers the full spectrum of information about marine electronics. Click on links to manufacturers for an A to Z list with no rivals in terms of knowing who makes what.

www.boatingwithdawsons.com

There's something for everyone here and this site is a collection of bits and pieces (and lots of links) of the aggregate wisdom of

the Dawsons, five generations of them in the business of boating. Drop in on this Canadian family to tap their experience and check out a unique collection of books, "e-lesson," the marketplace and what is touted as the "world's most complete library of old boat brochures." No cost to look; fees for publications may apply.

www.boat-links.com

Billed as the "Mother of all Maritime Links" and a.k.a. "John's Nautical Links List," this site is the work of a one-man effort by John Kohnen. It's a virtual encyclopedia of places to go and things to do for boaters. Links include: amateur boatbuilding and restoration projects; boatbuilding training sources; supplies; free boat plans; old engines; rigging, sails and more. Each link opens to other links and the ride is seemingly endless. No cost.

www.beta.circuitwizard.blueseas.com

Ever wonder about how you could quickly and easily calculate DC circuit wire and circuit protection sizes? Wonder no more as this beta test site is helpful to DIYers of all skill levels to allow them to quickly perform calculations and avoid making potentially dangerous guesstimates on these critical decisions. Cost? Your willingness to participate in a beta test site. [Ed: For a hands-on review of this program, refer to DIY 2008-#3 issue.]

www.boattest.com

Stop here for a virtual potpourri of information of boat performance tests and opinion, lots of video formats and online news-

letters addressing things like what to do with old flares and how to get tide times on your cell phone. Free for the clicking.

www.boats.com

Originally thought of as a place to shop for boats or to list one for sale, this site expands to many other helpful areas such as the NADA boat price guides, boat reviews and engine information. Click on the "research" tab and you are taken to the "Research Landing Page," aptly titled to reflect the range of topics you can access with a few more clicks. A bargain at \$0.

www.cruisingresources.com

If the "cruising life" is in your future, visit this site before you cast off. In one cruising couple's words, "... there's a whole lot of information out there for you ..." and a lot of it accessed through this site. Click to online articles, related websites, boats, vendors and offline articles. Read your way to the dream.

www.madmariner.com

This site is the "daily news" of websites for the recreational boater. Click to open the "front page" and you'll find sections for boat and equipment reviews, all written by proven experts, articles on seamanship, ownership legal issues, cruising destinations, projects and page after page of other timely reporting. There are forums, a blog and a link to videos. Take a test run for 30 days and then sign up for the \$16 annual subscription that entitles you to access all the ports and daily delivery to your email address.

RPARTS
REFRIGERATION PARTS SOLUTION
WE MAKE YOU THE EXPERT



"Do-It-Yourself" with RParts at unbeatable prices. We can help you fix a system or build it new.
Assembled DIY Kit shown

www.rparts.com

MONITOR

Fresh Water Cooling Systems

NEW
Easy Do-It-Yourself Conversion Kits

Ultimate Engine Protection
Lower Fuel Consumption

www.monitorpro.com
Call 1-800-334-4591
MONITOR PRODUCTS, INC.
15400 FLIGHT PATH DR. BROOKSVILLE, FL 34604

Cooler by Design

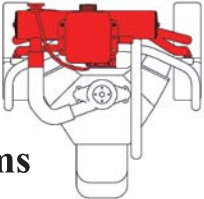

SEA FROST®

CHILLING SECRETS

Make it cold. Make it efficient. Make it durable; and most of all back it up with the best product support in the industry. Simple as that.

Whether it's a popular 12 volt BD or another from our full line of refrigeration systems, Sea Frost will build you a quality product custom tailored to fit your boat.

Sea Frost — The Thrill of the Chill.

Sea Frost, Route. 4, Barrington, NH 03825
Phone: 800-435-6708 or 603-868-5720 Fax: 603-868-1040
www.seafrost.com email: sales@seafrost.com



Here's a short list of a few other specialty shopping sites that DIYers especially will like when you are ISO ("in search of...").

www.marinepartsexpress.com

This is your online "stockroom" for Mercruiser, OMC, Volvo and Pleasurecraft marine and, on my first visit I counted at least 100 links on the home page that take you to other fascinating sites. I signed up for their newsletter and peeked at the chat room. Click into this site to enter engine techie heaven.

www.buyfittingsonline.com

Great catalog that is downloadable and won't get dog-eared or lost when you need it. Just open it on your laptop or desktop computer. Sign up for the free newsletter.

www.foamstore.com

When you need to "stuff it," this site has the foam solutions to meet your unique needs and all the ways and means to keep the stuffing where you put it, e.g. adhesives, buttons, welts and zippers.

www.marineengine.com

Despite a busy looking home page these guys packed a lot in it so you don't have to click and flip from page to page. All your clicking starts with this page and then it's on to infinity in an engine land of motors, drives, accessories and virtually anything that moves or makes a boat move.

www.oldmercs.com

Enter this site and you'll be directed with one click to www.east-coastmarineservice.com to access the Old Mercs Online Catalog, a 1940 to 1979 engine model guide and more. There are also links to parts' diagrams for Evinrude and Johnson parts dating back to 1968.

www.panbo.com

What a surprise this was for me! It's a blogging destination for the electronics geek and non-geek alike. Enter the blog to read detailed discussions about marine electronics and put your two-cents in, too. While I listed this site among the "mall" listings, it's not a place to buy electronics but where you go before you make a buying decision.

These are just a few of the many websites of interest to boat buyers and boat owners and surely to DIYers. Most boat builders have websites and they can be good resources for boat owners seeking information on current and out-of-production models. Check your boatbuilder's site for updates and information on their products and services.

Even the most envied tool collection of the consummate gearhead pales in comparison to what you can find on the Internet when it comes to shopping for "how-to" information. 🛠️

About the author: A self-appointed gearhead, Pat Kearns has traded in her dog-eared Northern Tool and Harbor Freight catalogs for a keyboard.

BETAMARINE US LTD

SMOOTHER • QUIETER

Our engines idle smoother & quieter because of our high inertia flywheel. This is one of many Beta Marine exclusive features that make our diesel easier to live with. Model BV1505 37.5 HP shown

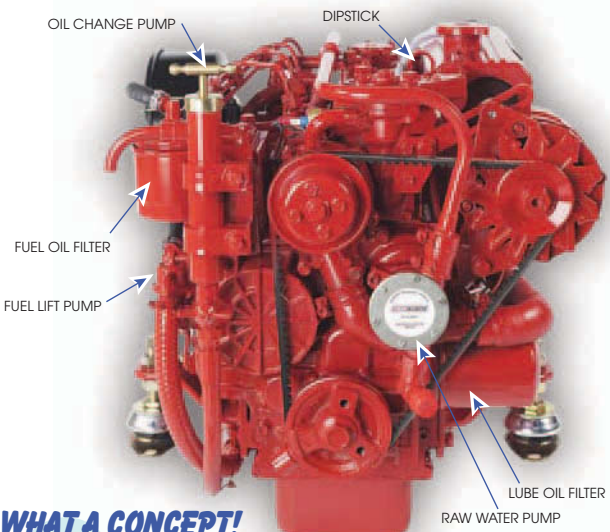

WHAT A CONCEPT!

Engineered to be serviced easily

- Beta Marine Superb Propulsion Engines using Kubota Diesels
- From 10-90hp including our famous Atomic 4 replacements
- Also available: Marine Generators up to 30 Kw

BetaMarine US Ltd
800-682-8003
info@betamarinenc.com
PO Box 5, Arapahoe, NC 28510
252-249-2473
www.betamarinenc.com

OUTDOORTEXTILES.COM

Purchase Online
Sunbrella, Nautolex, Strataglass, Grommets,
Thread and many other marine textiles

1-800-765-7011

www.outdoortextiles.com
info@outdoortextiles.com

PELA® Oil Extractors

Quick, Easy & Clean Oil Changes

Just Pump and Watch It Drain



PL-2000



PL-6000



PL-650



PL-14K

Capacities ranging from 0.6 gal (2.5L) to 3.7 gal (14L)

Tel: 1-888-272-7964 www.pelaproducts.com

PROP OPTIONS

Select the proper propeller to maximize power performance and reduce drag.

(above) A three-blade, fixed propeller in an aperture. (right) A two-blade, fixed sailboat propeller.

Story and photos by Bob Musselman

The first thing to keep in mind when considering propeller options for a sailboat is that it's a sailboat. It was designed to sail. Moving the vessel through the water via an internal combustion engine always involves some compromises.

That being said, there are ways to optimize the performance of a sailboat under auxiliary power and, with the same modifications, mitigate speed and efficiency losses under sail. You can't make these decisions until you assess your priorities for boat performance in both modes and understand how propellers work. After that, it's just a matter of how much money you are willing to spend.

If you spend most of your time cruising or you boat in an area with lots of tide and current or tight spaces, a three-blade propeller is your best choice. If money is no object, a feathering or variable pitch prop will appeal to you.

If efficiency under sail is most important, a two-blade propeller is probably best. A fixed, two-blade is the least expensive but spend more on a folding or feathering one and you get better performance with the least drag possible.

Proper Sizing

The golden rule of propeller sizing applies equally to sailboats as it does to powerboats. The correct propeller allows the motor to achieve its maximum rated rpm at full throttle. This means that the prop for an auxiliary diesel motor that is rated at 20 hp at 3,600 rpm must per-



mit the motor to achieve 3,600 rpm or very close to it at full throttle. Adjusting the number of blades, pitch or diameter affects that capability.

Sailors seem to be especially prone to question and abuse this rule. Many boaters reason correctly that more pitch at any given rpm results in more speed and, under those parameters, the motor is never run at full throttle. If that is true, why not increase the pitch so that the 3,600-rpm motor turns only 3,000 and moves the boat at the same speed as when run at a lower rpm? That must be more fuel efficient, right?

Probably not. The motor is designed to be most efficient when allowed to develop full rpm, even if it never runs at that rpm, so over-propping distorts the fuel consumption curve and the perception loses its value. The bigger issue is engine health. An overloaded engine works harder than intended at any rpm. Symptoms of this are overheating and smoke. The resulting engine illness

could cause premature engine death. The ultimate goal is to find a propeller that turns the engine at or very close to the maximum rated rpm at full throttle while achieving specific performance objectives.

Fixed Vs. Folding

The blades on a fixed propeller are cast in place at a fixed pitch and diameter. Most of the styles are derivative of powerboat designs so they work pretty well if properly sized and the boat is designed to accept the proper size. (More on this later.)

Two and three-blade, fixed props are common on sailboats and there are fixed propellers that are designed specifically for sailboat applications. Blades are long and skinny and the two-blade version can be vertically aligned behind the keel via a shaft lock to reduce drag when under sail but under power, these props aren't very efficient. Minimal blade area, while it reduces drag, is a drawback



The three-blade prop gives better performance under power and sail but the increase drag can reduce boat speed as much as 1.5 knots when sailing.



The “round” or symmetrical, three-blade, fixed propeller on the left provides better performance in reverse than the asymmetrical prop on the right. This powerboat design, however, works better in forward and is most commonly available.

when you’re trying to push a large displacement vessel.

Most three-blade, fixed props appear the same as powerboat props. The typical skewed blade propeller works well on a sailboat in most applications, though a symmetrical, round blade propeller can be a better choice as it works better in reverse. Better availability and cheaper price, however, makes the skewed style more common.

The “keep it simple, stupid/sweet-heart” rule of life points to a fixed propeller. They are readily available in many sizes, easy to repair and modify and relatively inexpensive. That’s why you’ll see fixed propellers on a majority of sailing vessels.

Fixed propellers, however, create drag, especially three-blade props that can’t be locked behind the keel. The speed loss under sail is usually estimated at

between .5 and 1.5 knots. There are propellers more specifically designed to lessen drag for sailboats.

Folding propellers are made so that the blades open up when power is put to the prop and then fold back when the boat is under sail, reducing drag significantly. Some are geared so that the blades move together. Some less expensive models do not, resulting in the nickname “flop prop” because the lower blade can flop open under sail and create unwanted drag. The moving parts on folding props are subject to wear so, over time, they tend to get mechanically loose. That causes vibration and noise and it aggravates the wear factor.

Folding propellers are the least expensive of the sail-specific propellers that provide good drag reduction. Three and four-blade folders are best but the most common designs are the inefficient two-



(top) A two-blade, folding propeller in the sailing position. (bottom) A two-blade, folding propeller in the power position.

blade variety, which doesn’t provide the best forward progress and can be downright scary in a strong current or wind, or around tight docks, especially if horsepower is marginal.

Feathering propellers have a complicated, usually geared, mechanism that allows the blades to turn or “feather” parallel to the water flow when under sail. Under power, the blades turn with the shaft and lock into the proper pitch. Unlike folding propellers, some props allow changing the pitch for optimum performance, allowing adjustment if horsepower or weight changes on the boat. Many feathering designs are three-bladed, which gives good performance under power, as good or better than a fixed, three-blade in many cases.

Feathering propellers, however, are complicated and expensive. They require maintenance of seals and the gears that drive them and, sometimes, the prop end of the shaft must be custom machined to fit the propeller. Because of the bulk of the closure housing and the fact that some part of a blade is exposed to water flow, they can create slightly more drag under sail than a good folding propeller.

Where to Buy

Choosing a feathering or folding propeller is usually best done in conjunction with the individual prop manufacturers,



(left) A three-blade, feathering propeller in the sailing position. Note how the top blade lines up behind the keel. (right) A three-blade, feathering propeller opened up in the power position.

because they know the specific performance characteristics of their propellers best and can calculate the proper diameter and pitch for a specific application. Working directly with the source can be the best economy when spending on this level. A “do over” is expensive.

When buying a more common fixed propeller, consider a competent propeller shop but make sure it's one that understands the nuances of sailing vessels under power. You can usually identify a suitable shop if you don't hear a “click” sound and dead air when you mention that you have a sailboat and are looking for a propeller.

What Size Fits?

Most sailboats are designed to keep the prop small, which makes sense to minimize drag under sail. Because so many sailors spend much of their time under power, including maneuvering through bridges in a tide or wind or around other boats in a marina, a bigger propeller gives better control.

One big factor in equipping a sailboat with any type of propeller is how the boat was designed in the first place. Most boats have an aperture, the area created

to accept the propeller, bound top and bottom on some boats by the space between the leading edge of the rudder and the trailing end of the keel in full keeled boats; open on the bottom but bound by the hull above in other cases. Regardless, this aperture limits the propeller size.

How close should a propeller be to the bottom of the boat? The usual rule says blade tip clearance should be a minimum of 15% of the propeller diameter but sailboat installations often test or break that rule to maximize propeller size. Repowers often present a problem. A boat designed for a fast turning gas engine, like the venerable Universal Atomic Four, has difficulty accommodating a prop that matches a slower turning diesel engine with a healthy gear reduction. The new motor moves the boat around better and more efficiently but the gains may be minimized if the propeller size can't be optimized.

Most prop shops can make that optimal propeller calculation using simple computer models, which work well for displacement craft. It's not uncommon, however, for the optimum propeller to be something that the boat can't accommodate. A recommended size of 16 by 10 (16" diameter and 10" pitch) might turn

out to be 14 by 12, if 14" diameter prop is all the boat can safely swing.

In this case, a 14 by 12 will probably work but if maximum diameter is only 12", a 12 by 14 propeller, which would theoretically load up the same as the optimum 16 by 10, will likely be disappointing. The smaller diameter simply cannot be as efficient. A three-blade propeller would be highly recommended in an attempt to reign in some of that inefficiency.

Maintenance

Modifying or repairing a fixed blade propeller is generally simple for any prop shop. Repairing damage to folding or feathering props should be left to a specialized shop that has the proper fixtures to pitch and balance them; or deal directly with the manufacturer. A good marine machine shop can often fix the most common problem on simple folding props, which is a worn pivot pin. Drilling out and replacing with a larger pin usually fixes that.

Folding and feathering props have moving parts that require more specialized maintenance. Check seals and grease fittings at haul-out time. Better boat yards are familiar with the workings of these propellers.

When in doubt, consult the manufacturer for information on reassembly, which can be a bit tricky. I learned the hard way on my first feathering prop when I put it back together so that it had 0 pitch. The customer was not amused. 🤔

About the author: Bob Musselman is a 20-year veteran of the propeller industry and is the owner of Admiral/C&B Propeller (www.acbprop.com) in Tampa, Florida, a prop supplier that does not hang up on sailors.



Searching for parts for your boat?
We have the hard-to-find parts you're looking for

- Faucets, showers, sprayers & plumbing system fittings
- Water & waste holding tanks customized for your boat
- Interior & exterior halogen, LED & incandescent lights
- Drink holders, vents, blowers, port lights, and *much more!*

ReplacementBoatParts.com



PFD Service

Follow these steps to routinely inspect and service automatic inflatable PFDs. The life you save may be your own.

Story and photos by Jan Mundy

“Out of sight, out of mind” is the attitude many boaters have about their personal flotation devices (PFDs). While this is a careless safety practice with conventional lifejackets, it won’t pass muster with self-inflating PFDs that have become the favorite of many boaters. Reliability of these “devices” requires some owner maintenance. Indeed, if you are not conscientious about performing the required maintenance, you compromise your safety and that of others who depend on your due diligence to ensure their safety.

Of the various types of automatic inflatable PFDs, all deliver comparable in-water performance when deployed. The differences are in the firing of the inflation mechanisms. To simplify, the servicing steps on the following pages are for inflatable PFDs offered by Mustang Survival (www.mustangsurvival.com). Use these as guidelines if you own a competing brand with inflation systems that incorporate Halkey-Roberts inflators. (Look for the HR on the inflator.) As with any service, consult your owner’s manual for complete instructions. Many manufacturers offer manuals on their websites if you’re without the one that came with your PFDs.

The three types of Mustang inflatables, in order of price, are: Classic, Classic Deluxe

and Hydrostatic; the former is the most expensive. The first two are bobbin-style lifejackets that activate on water contact. Bobbins are made of compressed cellulose and this powdered paper absorbs moisture. Every bobbin is date stamped and has an operating life of three years. Albeit your owner’s manual states to replace the bobbin every three years, Mustang recommends disregarding the date and replacing it every year to avoid a misfire. A bobbin costs \$10 or less and replacing takes but a few minutes (See “Annual Bobbin Replacement” below). Check that the expiry date on the replacement bobbin is current or less than three years old.

Hydrostatic-type PFDs inflate when submerged in 4" (101mm) of water and are unaffected by water contact or humidity so there’s no chance of a misfire. Provided they are not inflated, such lifejackets do not need servicing for five years from the date stamped on the inflator.

Servicing inflatable PFDs entails a quick visual inspection before every use; a more comprehensive service every two months and, provided the lifejacket was not inflated, an annual re-arming of the bobbin types at the start of each new boating season or re-arming of hydrostatic PFDs every five years. Record these service

dates in permanent ink on the Care and Storage label on the PFD, as well as in your maintenance log. For the hydrostatic types, record the expiry date stamped on the inflator as well.

If you are not confident in the self-inspection and servicing of your inflatable PFD, take it to a qualified dealer for professional servicing.

Before Every Use

Before donning your lifejacket, always examine the status indicator ensuring it is green. If the indicator is red, the mechanism has been fired or is incorrectly fitted and the inflator requires service (see “Annual Bobbin Replacement” on the next page). Remember, green for “go,” red for “stop.” Check that the manual pull-tab is accessible. Inspect stitching, straps and hardware for damage or excessive abrasion and wear, especially the coated nylon cover that protects the air cell from harmful UV and chafe.

Two-Month Service

Every two months perform a two-part leak test on your inflatable lifejacket. Locate the oral inflation tube, remove the dust cap and blow into the tube, inflating the PFD until firm. Hold the valve under water and

if bubbles appear, deflate and reinflate to test again. Replace the dust cap. Leave the lifejacket fully inflated for 24 hours. If it loses air or the valve leaks, consider replacing or take it to a Mustang dealer for evaluation and/or servicing. Deflate and repack according to the manufacturer's instructions.

Annual Bobbin Replacement

Perform the following annual service of Classic and Classic Deluxe type PFDs at the beginning of each boating season. To begin, place the inflatable PFD on a smooth, flat, clean surface and wipe off any water.

Mustang Classic or 6F Halkey-Roberts Types



Open the Velcro tabs to expose the automatic inflator.



Remove and inspect the cylinder. Replace if corroded or the top is pierced by the firing pin.



Turn the auto capsule counter-clockwise and remove and discard the bobbin.

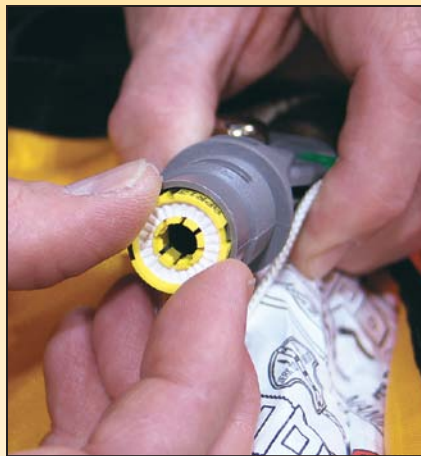

Drop in the new bobbin, which is keyed so it's impossible to install incorrectly.



Screw on the auto capsule by hand only until just snug tight. Never tighten with pliers or you risk an accidental firing. Reinsert the cylinder after checking that there is no debris in the receiver and hand tighten. Do not over tighten.



Ensure the service indicator is green. If it shows red there is a problem with the bobbin or the auto capsule or cylinder is not fastened properly. Secure all Velcro tabs. Perform the Leak Test (see "Two-Month Service" on the facing page). Follow the above steps to re-arm a PFD after inflation, except install a new cylinder.

Mustang Classic Deluxe or 1F Halkey-Roberts Types

Unfasten the Velcro tabs and turn the PFD inside out to expose the inflator.



Turn the cylinder 1/8 turn counter-clockwise and pull off.

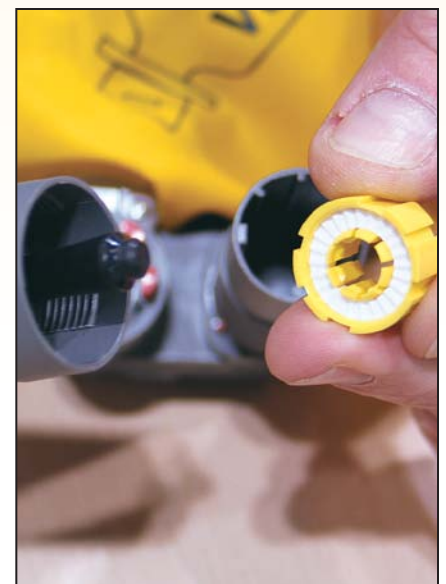

Turn the auto capsule counter-clockwise to reveal the bobbin. Discard the bobbin.

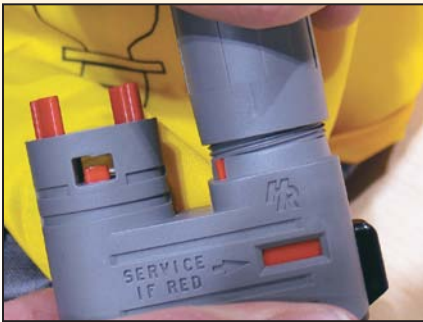

Drop in a new bobbin, aligning the slots, and hand tighten the capsule until it butts up against the housing.



Reinstall the original cylinder if there is no evidence of corrosion or damage, a worn O-ring or a broken sensor ring that indicates the cylinder was fired. Align tabs on cylinder with inflator housing and twist clockwise 1/8 turn to a full stop.

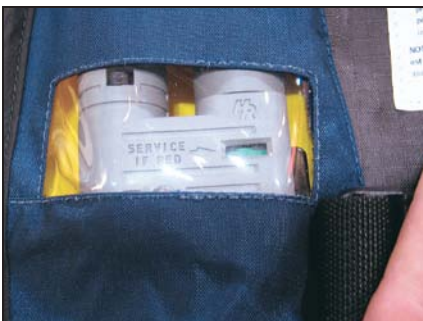

Reposition the inflator under the inspection window. Ensure the service indicator is green. Red indicates that there is a problem with the bobbin or the auto capsule or cylinder is incorrectly fitted. Secure all Velcro tabs. Perform the Leak Test (see "Two-Month Service" on page 40). Follow the above steps to re-arm a PFD after inflation except install a new cylinder.

Five-Year Re-arming

Hydrostatic-type PFDs require re-arming every five years or after activation.



Check the expiry date on the hydrostatic inflator. This inflator has a 2013 expiry date. Since sensors are not "smart" they remain green regardless of the expiry date and only turn red when inflated.



For the five-year service, you need to purchase a Re-arm Kit (about \$65) for your particular PFD model. The kit includes a special key needed to release the locking mechanism.



Unzip and turn the PFD inside out to expose the inflator. Lay the PFD on a clean, flat surface. Insert the metal key between the yellow cap and black locking ring tabs (shown by the arrow) and move it a 1/4 turn counterclockwise. Continue to turn the black locking ring and then lift off the yellow cap. Discard the cap.

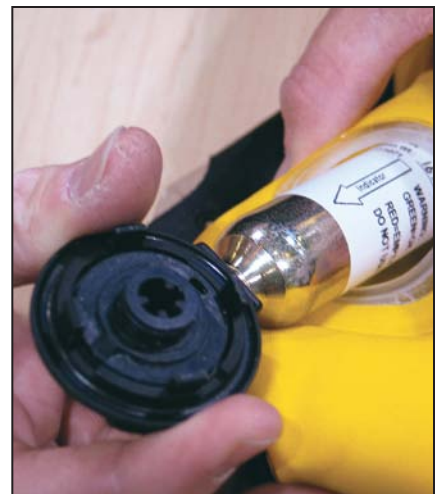

Squeeze the clear "rubber" sealing ring on the lifejacket to elongate the opening and pull out the inflator body with the attached cylinder. Discard the cylinder.



Insert the new cylinder. Align the tabs of the replacement yellow cap with the inflator body, press down firmly against the sealing ring and turn the black locking ring clockwise. Pull on the cap to ensure it's locked onto the inflator body. Check that the status indicator is green and the manual inflation pull-tab is not tangled. Restuff the inflator and fasten the two-way zipper. Perform the Leak Test (see "Two-Month Service" on page 40).



Inflatable lifejacket testing is crucial to ensure your safety on the water. If you have never performed any of the foregoing maintenance, do so now. Your life may depend on it!

About the author: Jan Mundy is editor of DIY.

Thanks to Al Thompson of Allan Thompson & Co., for assistance with this article.



Make Old Fiberglass SHINE LIKE NEW!

Before

After

Rated #1
By Practical Sailor & Powerboat Reports

- Restore oxidized fiberglass
- Easy to apply - wipe on, no buffing
- Won't wash off, not a wax
- Lasts over 12 months
- Guaranteed

Never Wax Again!

VISIT OUR WEBSITE FOR A VIDEO DEMO

www.poliglowproducts.com
1-800-922-5013 • 1-772-595-5755

Tideminders™

Roll With the Flow

A simple yet effective mooring line control system.

- A string of high density polyethylene balls threaded onto your mooring line.
- TideMinders roll up and down any size piling, offering constant tension with built-in shock absorption and eliminating the need to constantly adjust the lines.
- TideMinders system embodies 9 balls, which provides protection for boats of any size
- Balls float, come in blue, white, orange or black, and they will accept a 1" line.

Installation requires no tools.
Just tie a Figure 8 knot and you're ready to use the Tideminders system. One package of nine Tideminders balls gives you protection on any size piling.

For more information contact:
Dr. Shrink, 315 Washington St., Manistee, MI 49660
Phone: 800-968-5147 • Fax: 231-723-9586
 drshrink@dr-shrink.com • www.dr-shrink.com.

The Wheel TOUCH

A wheel upgrade to a soft touch makes helm duty much more enjoyable.

By Jan Mundy

When shopping for a boat, whether new or used, most buyers spend hours comparing cabin layouts, evaluating fixtures and furnishings, examining hardware, accessing storage and amenities. Considering the hundreds of boat shows that I have attended, I've never once heard a would-be buyer direct their attention (or mine) to the one piece of equipment they will inevitably touch the most: the steering wheel. After all, a wheel is a wheel, right? Wrong. Steer your boat on a lengthy passage on a cold night and an upgrade might be the top item on your wish list.

Most boaters take wheels for granted, making do with what the boatbuilders supply. The reality is that builders sell you a \$100,000 boat with low budget steering wheel that is slippery, cold to bare hands, sure to eventually corrode and with welded spokes that may break when driving in rough conditions at high speeds.

Besides comfort, there are other reasons for a wheel upgrade and visibility and space issues are the prime factors. Exchanging a large powerboat wheel for a smaller one eliminates interference from closely spaced engine controls or can gain unobstructed views and access to dash-mounted gauges and electronics situated forward of the wheel. Swapping a traditional sailboat wheel for an elliptical-shaped one gives the helmsperson unfettered access to throttles and shifters without having to reach through the wheel spokes. When refitting an older boat, there's nothing trendier than the look (and feel) of a contemporary stainless-steel wheel or a fashionable wooden wheel, finished to complement the brightwork around the helm area, with the added benefit of thermal protection from cold.

Regardless of the reason for upgrading, the comfort factor of a high quality wheel is greatly undervalued until you've savored the difference.



Power Options

When we ordered our new powerboat, a Rosborough RF-246, we asked the builder to omit the oversized, 18" (457mm) stainless-steel destroyer wheel. One reason was that we didn't like this style but, more importantly and an item learned from experience operating our cuddy cruiser, we wanted a wheel with a more comfortable grip, one that didn't require a neoprene wrap to isolate fingers from the cold and one that we had seen at boat shows; namely, an Edson.

Based in Massachusetts, Edson (www.edsonmarine.com) continues to outshine the competition. Its powerboat wheels are made of one-piece cast, highly polished 316 stainless steel with no welds or sharp edges that will flex, corrode or break. For the utmost functionality, Edson adds the ComfortGrip to this construction. It's a grooved, tactile elastomer pistol grip inserted underneath the stainless-steel rim. Made of sanoprene, the same stuff as the high-end OXO Good Grips kitchen



Jan Mundy



Baltic



Jan Mundy



Edson



Jan Mundy



The author opted to replace the 18" (457mm) destroyer wheel, so common on many pocket trawlers, with a smaller Edson 14.5" state-of-the-art wheel with ComfortGrip and PowerKnob. "The ultimate steering experience."



Edson

Edson non-slip cushioned grip provides precise control and offer the ultimate in comfort for cold-weather driving.



Jan Mundy

Do-it-yourself leather wheel covering kits adds luxury and comfort to stainless-steel wheels. The ComfortGrip option (inset) adds cushioning and thermal insulation from the cold.

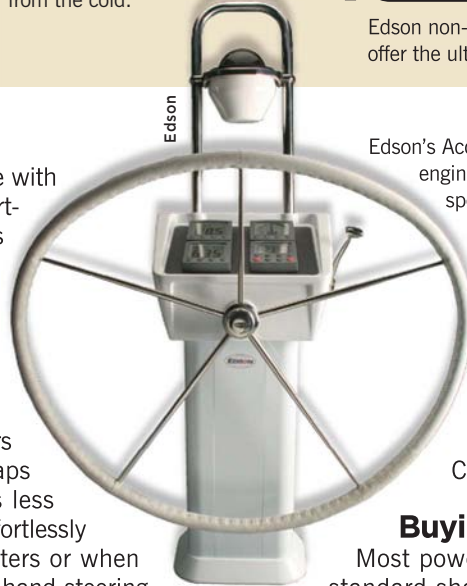

Edson

and gardening tools developed for people with arthritis, this insert delivers a soft, comfortable, non-slip cushioned grip that provides precise control and insulates hands from the cold.

If buying a new wheel is not in the budget, then consider purchasing a PowerKnob. Designed after the "suicide knobs" (a.k.a. necker or granny knobs) mounted on car steering wheels 50 years ago, the free-swiveling PowerKnob straps onto a boat's steering wheel rim. This less than \$90 option makes it possible to effortlessly maneuver any powerboat in tight quarters or when backing down a slip without hand-over-hand steering to spin the wheel.

After consulting with Edson, we chose a ComfortGrip wheel with integral Power Knob, 3-1/2" (88mm) smaller than the factory installed destroyer wheel for our new boat. After a summer of cruising, we can attest that time spent holding this wheel is akin to sleeping on an airbed. Steering just doesn't get any better than this.

Leather Makeover

The most popular upgrade for stainless steel sailboat wheels and even found on some powerboat wheels, is leather covering. You have the option of shipping your wheel to Edson and having it professionally covered or you can create a luxury wheel by purchasing an Edson kit, with or without the ComfortGrip, and doing it yourself.

Kits include pre-punched gray or tan colored orthopedic grade cowhide, a specialty leather than remains supple even in the most extreme conditions, double-sided sticky tape, thread, needle and complete instructions. The ComfortGrip version has contoured, closed-cell neoprene foam that cush-

ions the wheel and forms warm-to-the-touch finger grips on the inside of the wheel rim. Cost for a 30" (762mm) wheel is \$159; the same size kit with ComfortGrip is \$249.

Buying New

Most powerboat steering wheels, new or old, fit a standard shaft size and this simplifies the purchase process. Wheels have a 3/4" tapered hub and, for the 1% of powerboat helms with a 1" straight shaft, wheels can be custom bored for an additional charge. Sailboat wheels are more complicated but Edson has a database of all boat models and their corresponding wheel shaft size to make buying easy. Just contact Edson (tel: 508/995-9711; info@edsonintl.com) with your boat's make, model and year built.

The steering wheel is the one item handled the entire time you're driving the boat. The cost difference between a cheap wheel and a comfortable wheel is purely a matter of comfort and function. With a new, contemporary wheel or one of the options mentioned above, you can eliminate the tedium of steering and improve your overall boating experience. The next time you grab the wheel you'll say, "This feels really good." Why settle for less? 🍷

About the author: DIY's editor Jan Mundy and her husband and DIY's cofounder, Steve Kalman, are planning to depart on a cruise of North America's Great Loop this fall onboard *Jessie M*, a new semi-custom built Rosborough RF-246.

BOARDING ASSISTS

Some ideas for better holding, better footing, better hopping-all-around and safer boarding.

an up and/or over affair and, as we age, the hopping and jumping gene may have lost its oomph. What boater has not hit the drink a least once, the result of a misjudged distance or a faster-than-guesstimated rate of drift or a simple, overconfident "I can do it" gone wrong. Mostly, such a dousing is dismissed as an embarrassment but it can sometimes result in serious injury or be deadly in frigid waters in winter or if a person is knocked unconscious on the way down. With that in mind, you might benefit from some solemn thought about how you get aboard.

Gangway or Gangplank



Large powerboats often use an aluminum gangway that resembles a cruise ship's gangway, complete with railings and rollers.

At the literal bottom of the list of boarding helps is the gangway, a traditional idea that has evolved with many variations. Large powerboats are often equipped with an aluminum gangway that resembles a miniature ship's gangway, complete with railings and dock rollers, which allow for tide rise and fall. Boat owners can buy a telescoping version that extends over 6' (1.8m) to suit their application.

Boarding Steps

Gangways do not suit all situations, as evidenced by the many variations to be found in the popular category of boarding steps. From boat steps with molded-in non-skid to wooden build-it-yourself platforms, designs abound. Two or three-step models seem most popular and though specific plans vary, below are some general guidelines.

The standard for a step rise in such a structure for a boat is no more than 12" (304mm) per ABYC H41. Use pressure-treated wood and top the



(top) A two-step design with aluminum handrail attached. (bottom left) Outdoor carpeting for slip-resistance and traction is commonly seen where steps are protected from the elements. (bottom right) A substantial wooden handrail added to larger platforms.

Story and photos by David and Zora Aiken

When you first get into boating, you don't give much thought to getting into or onto the boat. The starter boat is often a fairly small open boat, so it's a

short hop, step or jump down from the dock, minding only the standard caution to land in the middle of the boat. As boats get bigger, boarding becomes

steps with wood or rubber treads or strips of nonskid tape. Outdoor carpeting is often used to cover the finished steps, which works if the boat is stored in a boathouse but not so well in an outside slip where repeated soaking from rain may hasten rot. A back panel hinged to the steps allows access to the space underneath for storing small items. Handrails are a good addition to the step. Regardless of construction, it must be sturdy enough to withstand heavy loading and it must be securely attached to the dock.

There are lots of ways to secure this structure to the dock and still be able to remove or move the platform when desired. As many marinas nowadays forbid such structures because the marina winds up taking the hit when someone falls, always ask first before installing such a structure.

Mats



Boarding mat securely affixed to the dock minimizes the chance of its slipping underfoot.

Even where steps aren't necessary, a boarding mat may be helpful. Whether the mat is a carpet sample, a hard-rubber "welcome" mat, a square of plastic "grass" or a flemished line stitched into a mat, it should be screwed or fastened to the dock so it cannot slip under foot.

Onboard Steps

On the boat, a few things can make the boarding site safer. Add strips of non-skid tape, either on top of the toerail or on the deck itself at the usual boarding place or attach teak treads onto the toerail.

Grabbers

Whether on the boat or on the dock, it helps to have something to grab for support. Often, the boarding site is close to a dock piling. If this is the case at your home slip, bolt a handle on the piling to



Wood strips securely fastened provide a safe boarding site.



A sturdy marine-grade grabrail mounted on a dock piling helps to ensure safety when boarding or leaving the boat.

help steady yourself when getting on or off the boat. You could use a very nautical teak grabrail and there are many off-the-shelf grab rails available in chandleries.

Clear the Way

When possible, sailors should lower the lifelines at the boarding site, as climbing over lifelines is an invitation to fall that could seriously hurt someone.

If your boat is not equipped to open and drop the lines, put in a gate, or add a pelican hook to attach the lifeline to the stern pulpit. The Johnson Marine Hand Crimp (part 53-210) makes it easy for the DIYer to compress stainless-steel hand-crimp fittings.

To drop the line to deck level, unhook it and pull it loose until the lifeline touches the deck at the boarding site. Tie it loosely to a stanchion if necessary



Conventional lifeline gate design fitted with pelican hooks.

to keep it out of foot's way. Remember to put the line back on the hook when everyone's on board. ⚠️

About the authors: Frequent contributors to DIY, David and Zora Aiken have been liveaboards for more than 20 years and are authors of *Good Boatkeeping* and *Cruising: The Basics*.

Depowering an '80s Cruiser

9

Sometimes it is better to replace an engine than repair it when one factors age, costs and a possible change in engine horsepower.

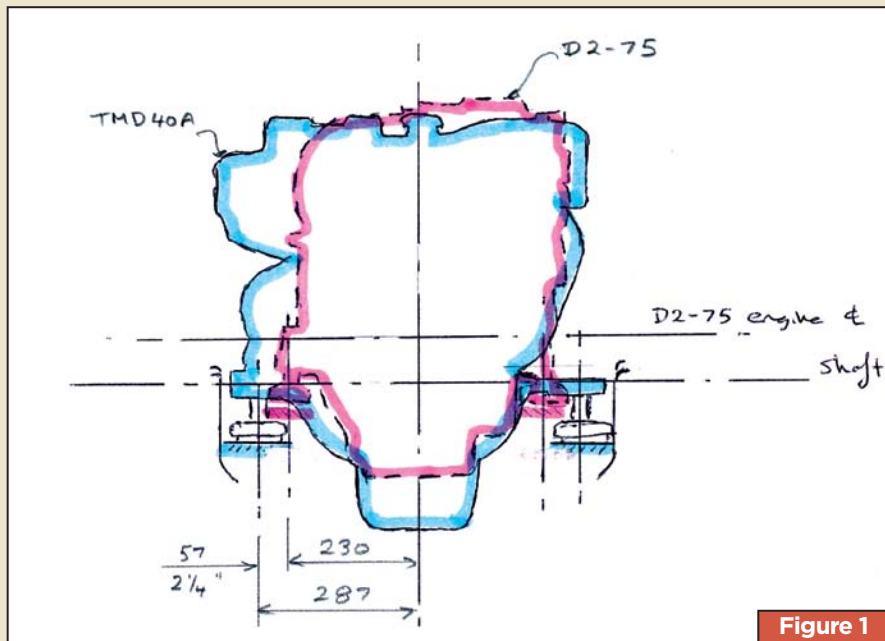

Outline sketches of new (pink line) and old (blue line) engines.

Story and photos by Don Armstrong

When an exhaust valve stem broke and damaged a piston in the diesel engine in *Veleda V*, our Great Lakes 33 trawler, we were faced with a decision to repair or replace. The old Volvo TMD40A engine had never been out of the boat since new in 1982 and, with more than 4,000 hours of run time, it would be prudent to replace bearings and overhaul other engine components when replacing the piston. Removing the engine would require some dismantling and, as expected, the repair estimate from our local yard was enough to motivate us to look at other options, one of which was to repower.

This engine is rated at 117hp but we do not run the boat above the 8-knot hull speed. Our research showed us that operating the boat this way required less than 30hp in calm water. The option of installing a smaller engine was worth considering and it appeared that a four-cylinder Volvo D2-75 with a 2.8:1 reduction transmission would be a very good match for the boat using the old propeller and shaft. This engine's 75hp rating should provide enough power to

maintain a good speed even in rough water.

Some sketches showed that the smaller engine would fit well (**Figure 1**) so we decided to "depower." Because the new engine is slightly more than half the weight of the old one, it was mounted well forward to maintain trim and to provide good access for maintenance. This left a gap between the old shaft coupling and the new motor coupling.

As an engineer, I've always disagreed with the common practice of using a solid shaft coupling with an engine on flexible mounts because any movement of the engine puts the thrust bearing out of line. I decided to use the old propeller shaft with an 18" (457mm) jackshaft between the old shaft coupling and the engine, with two flexible connections.

To stabilize the long propeller shaft required a steady bearing close to the old shaft coupling. This steady bearing could also have acted as a thrust bearing but, because the transmission is designed to take thrust loads, I decided to allow the steady bearing to slide in its housing. This allowed the bearing

BLISTER FACTOR
INDICATES THE DEGREE OF DIFFICULTY WITH TO BEING THE HARDEST AND 1 BEING THE EASIEST.

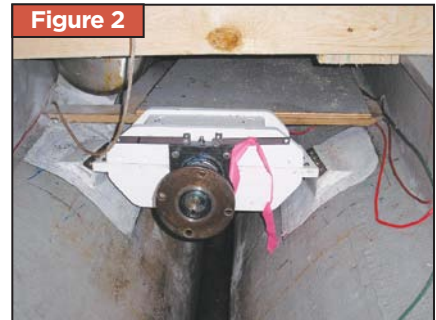

New steady bearing in place.



Typical temporary cabin sole support.



Engine hoisting arrangement.

and its support to be of much lighter construction.

I decided to tackle the job myself. The first step was to install the shaft steady bearing.

Figure 5



Temporary power using custom swim grid bracket.

Figure 6

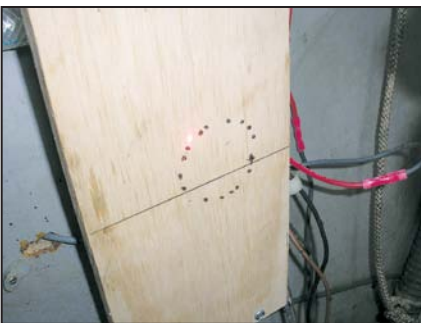

(top) Laser pointer to establish the shaft centerline. (bottom) The center of the circle is the centerline.

Bearing Makeup

To maintain shaft alignment, the steady bearing was installed before removing the old engine. The split steady bearing support was made of 3/4" (19mm) plywood, bolted and glued for strength and designed so that the shaft passed through the center of the support to avoid bending forces on the anchor blocks, which were bonded to the hull (Figure 2).

The bearing housing was machined from 1" (25mm) steel plate and bolted to the support block. Clearance was provided to allow the bearing outer race to slide freely, with help from a grease fitting in the housing block. A spherical ball bearing with two seals,

DIY BILL OF MATERIALS

Item	Cost
Engine - Volvo D2-75, with instruments.....	\$14,000
R&D flexible couplings.....	\$390
New shaft with couplings.....	\$610
Aluminum engine mounts.....	\$230
Exhaust hose.....	\$100
Water and fuel hoses.....	\$40
Use of marina hoist (2 lifts).....	\$160
Bearing housing.....	\$100
Bearing and adapter sleeve.....	\$160
Lumber for hoist and planks.....	\$150
Chain block rental.....	\$40
Miscellaneous plywood, fasteners, etc.....	\$200
Alignment bar.....	\$40
Total for project.....	\$16,220

Item	Labor
Strip old engine.....	8 hours
Build lifting frame.....	6 hours
Strengthen cabin sole.....	2 hours
Remove engine.....	4 hours
Remove old mounts and seal stringers.....	6 hours
Built engine template and set centerline.....	12 hours
Install new engine mounts.....	6 hours
Modify fuel lines, cooling water, battery cables, etc.....	12 hours
Install new engine and connect up.....	8 hours
Total labor.....	64 hours

lubricated for life, was used. The load on this bearing is very light (just the weight of the shaft) and the design allows for up to 3 degrees of misalignment without affecting the seal. It is fitted to the 1-1/2" (38mm) shaft with a tapered adapter sleeve that allows for easy removal. A similar bearing was installed at the center point of the 9' (2.74m) shaft some years earlier to minimize vibration and it proved to be reliable.

Engine Removal

Once the new bearing was in place, the old engine was removed. This was done with the boat in the water. The plan was to lift the engine above the cabin sole and then slide it into the cockpit where it could be lifted with a dockside hoist.

Engine heat exchangers were removed to allow the block to pass through the cabin door and additional supports, installed under the cabin sole and cockpit, carried the 950lb (431kg) engine weight (Figure 3). Two 8' (2.43m) long, 4" by 4" (101mm by 101mm) posts were mounted on the stringers along-

side the engine with a beam made of two 2" by 6" (50mm by 152mm) planks fitted at the top. These were braced to the cabin sides and to a stout grab rail for stability. A one-ton chain hoist lifted the engine (Figure 4). When it was high enough, a fabricated wooden cradle was bolted to the engine, which was then lowered on to 2" by 10" (50mm by 254mm) planks. With the engine on its cradle, a simple cable puller was used to slide it into the cockpit.

The 6hp tender outboard mounted on a wooden bracket designed to fit the swim grid (Figure 5) powered the boat to the marina hoist where the old engine was removed. This setup was also used to get the boat home when the engine broke down, saving several hundred dollars in towing fees. The top speed with this small engine is about 4 knots. Not bad, considering the boat's dead weight is about 14,000lb (6,350kg).

Mount Placement

Next, we prepared the stringers for installing new engine mounts. The old steel engine mounting brackets were



Figure 7
Template for locating the new engine mounting brackets.



Figure 8
Marking the stringers for the new brackets.



Figure 9
Ready for the new engine.



Figure 10
New shaft extension with R&D flexible couplings installed.

removed. The bolt holes in the stringers were plugged and sealed and the bilge cleaned thoroughly.

An accurate centerline was needed and, to establish this, a laser pointer was mounted on the propeller shaft coupling, pointing forward (Figure 6).



(top) Pulling the new engine into the cabin.
(bottom) Lowering the new engine into place.

As the shaft was rotated, pencil marks recorded the position of the laser spot on a target board on the engine compartment forward bulkhead and the centre of the circular marks gave an accurate centerline.

Because the new engine was still a month away from delivery, I used drawings from the Volvo website to build a plywood mock-up of the engine mounting arrangement. Using this pattern and the shaft centerline enabled me to accurately locate the new engine mounts (Figure 7). Mounts were made of 4" by 6" by 3/8" (101mm by 152mm x 10mm) aluminum angle with welded brace. These were clamped under the

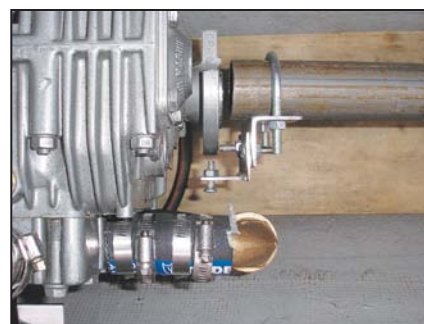
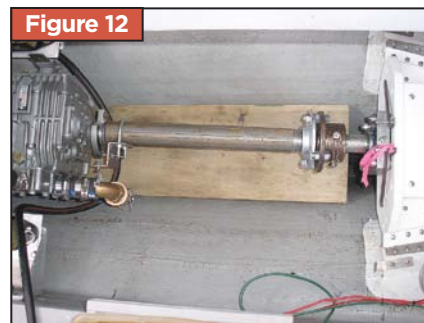

(top) Alignment bar. (bottom) Close-up of alignment bar detail.



Completed installation.

plywood pattern and the stringers were carefully marked for drilling (Figure 8). After bolting the new engine mounts to the stringers, the plywood template was placed on top of the mounts and used to accurately drill the bolt holes for the engine supports (Figure 9).

A local shop machined the new jack shaft. Because the couplings on the new engine and the old shaft were not the

PROJECTS WANTED

If you would like to share one of your own boat-tested projects, send your articles to DIY PROJECTS via mail or e-mail. Include a brief explanation and photos and/or sketches (don't worry, we'll redraw the art). Also, please include your mailing address and a daytime phone number or email address. If we publish your project, we'll send you between \$50 and \$350, depending on the published length.

DIY BOAT OWNER
THE MARINE MAINTENANCE MAGAZINE
PROJECTS

P.O. Box 22473,
Alexandria, VA 22304
or E-mail: tech@diy-boat.com

same size, two different R&D flexible couplings were purchased and fitted to the jack shaft (**Figure 10**). Before the engine was delivered, the fuel system was modified for the new engine and battery cables and engine controls were rerouted. The old exhaust system was in good condition and the correct size, so all that was needed was a new 3-1/2" (88mm) exhaust hose from the new engine to the muffler.

Engine Fit

The new engine was installed with the same lifting arrangement as was used to remove the old engine (**Figure 11**). The accurate positioning of the engine mounts paid off. The new engine, the new jack shaft, fitted and aligned, new exhaust hose, raw water cooling hose, fuel lines, battery cables and controls all were installed in less than 8 hours. An alignment bar (**Figures 12**) was used to span the gap between the engine and propeller shaft couplings to accurately line up the engine before installing the jack shaft.

The only part of the project that required more than one person was when using the dock hoist to lift engines in and out of the cockpit. The finished installation (**Figure 13**) allows for good access to all maintenance points.

On-water Performance

The engine tested well, with very little vibration, and ran reliably during our summer cruising. The maximum boat speed with the old 117hp engine had been 10 knots and it was pleasing to see that the reduction to 75hp reduced this only slightly to a very respectable 9-1/4 knots. The new engine can easily maintain the old cruising speed in both calm and rough conditions. Fuel consumption is down 20% to about 1.2 gallons per hour. 🚩

About the author: Don Armstrong is a retired mechanical engineer with over 50 years of recreational boating experience in both powerboats and racing sailboats in New Zealand and Canada. He and wife Cheryl live on Vancouver Island, BC.

Last Year, More Than 100,000 Boaters Needed Assistance.



You may think you'll never need a tow but odds are good that you will at some point—just ask the 100,000 boaters that were towed last year. That's why it pays to have Unlimited Towing from BoatU.S. Towing Services. With the average price of a tow around \$600— it's better to pay a little now rather than a lot later.

- ✔ On-the-water towing, soft ungroundings, jump starts & fuel delivery
- ✔ Applies to all recreational boats you own, borrow or charter
- ✔ 24/7 dispatch and assistance
- ✔ No claim made on your hull insurance
- ✔ Towing provided by TowBoatU.S. and Vessel Assist Pacific

BoatU.S.
TOWING SERVICES

To join, call
800-888-4869
or visit **BoatUS.com**

Look For the RED Boats of TowBoatU.S. and Vessel Assist!

*Service provided during normal boating seasons. Details and exclusions can be found online at BoatUS.com/towing or by calling.



Lasdrop
SHAFT-SEALS

The Most Advanced. The Most Reliable.

Shaft sizes 3/4 to 8"
Rated "Best" by Powerboat Reports
Maintenance free
3-year warranty
Stuffing box replacement
Dripless operation
3 models to choose

www.lasdrop.com
toll free 800.940.SEAL
direct 586.468.3729

Made in the USA

A Timeless Sole

9

Replacing interior carpet with teak and holly veneered plywood turns this aged cruiser into an elegant yacht.



Rather than an exact carpet replacement, the new floor was reengineered to make use of the unused space beneath the dinette, adding extra floor storage.

Story and photos by Paul Drouillard

After installing new carpet in our 1978 Trojan F26, we realized that it didn't do justice to the overall look of the classic interior and it trapped tracked in dirt. Since we've always liked the look of teak, we decided to make installing a teak and holly veneered plywood sole our winter project. My wife, Margaret, and I prefer to do any needed work on our boat ourselves but we're not skilled wood workers. Though we didn't have to buy any special tools for this job, we did borrow a router. The tools required were a circular saw, a jigsaw, table saw, router, clamps, drill, screw gun and drill press with drum sander bit.

Instead of laying individual pieces of solid teak and holly we chose 1/4" (6mm) plywood with a teak and holly veneer. This covered the existing floor space (galley, dinette area and vee berth area) easily and also bonded well to the plywood main cabin sole and companionway steps. It was also easier to create in-floor storage hatches out of a large panel versus individual strips.

It's important to maximize usage of all wood while keeping the grain running in the same direction. This determined the number of plywood sheets needed for the project. To keep the bilge accessible for cleaning and service, we replaced the original hatches with one piece of 3/4" (19mm) marine plywood.

The stringers were leveled to reduce squeaks and provide additional support. To do this, we marked a straight line using a rotary laser level around the perimeter of the floor being replaced. Working from these lines we used a straight edge to identify the high and low spots and raised or lowered the center floor supports as needed to level the floor.

Pattern Making

Old floor pieces were used as templates to cut the marine plywood sub floor. We then used the new sub-floor piece as a pattern to cut the new plywood pieces. Once cut, both the sub-floor and new pieces were laminated together using

Bulldog PL 200 adhesive, applied with a caulking gun and spread with a serrated trowel over all surfaces. These pieces were clamped together and left to cure for three days.

Customizing the Dinette

As the dinette floor was not removable, it was laminated in place. After removing the carpet and table hardware, we made a cardboard template. While doing this, we created additional under-floor storage by building an access hatch and means of supporting that hatch under the dinette seat. We now store dive masks, fins, snorkels and board games there.

Cutting a hole into both the new sub floor and teak and holly-faced plywood required some edging to achieve a clean look. To do this, we chose pre-cut teak, L-shaped moldings, 1" by 1" by 1/4" (25mm by 25mm by 6mm), the same thickness as the teak and holly plywood so they butted together evenly. The purchased molding had a 1/8" (3mm) raised, round edge, which we removed with a router where it met the teak plywood.

To make the molding work, the hole in the existing plywood floor was cut 1/2" (12mm) smaller than the corresponding hole in the teak and holly plywood. To do this, we first drilled two pilot holes in the holly strips for ease of matching wood filler for future use.

The teak and holly panel was then screwed down to the marine plywood sub floor and the location of the hatch opening marked on the plywood. After marking the opening, a 3/8" (9mm) pilot hole was drilled in each corner within the lines. This gave a place to insert the jigsaw and cut the opening into both the sub floor and teak and holly piece at the same time.

The cut piece was set aside and a piece of the trimmed molding was dry fit in the opening with a line drawn along the top inside edge to mark the notch required in the teak ply to support the molding. This notch measured 1/2" (12mm) larger all around than the opening in the sub floor. We now removed the screws holding the teak ply and subfloor together and, with the plywood piece clamped on a worktable, used a jigsaw to cut the opening to the exact size. Next, the cut piece was fit with the help of some minor trimming



Gluing and clamping of teak and holly floor to marine plywood subfloor.



Hatch opening detail with back molding in place. Note corner detail.



Teak and holly floor is laid over the original carpeted space below the vee berth and a hatch cutout for bilge pump access. Note bulkhead prepped for veneer.

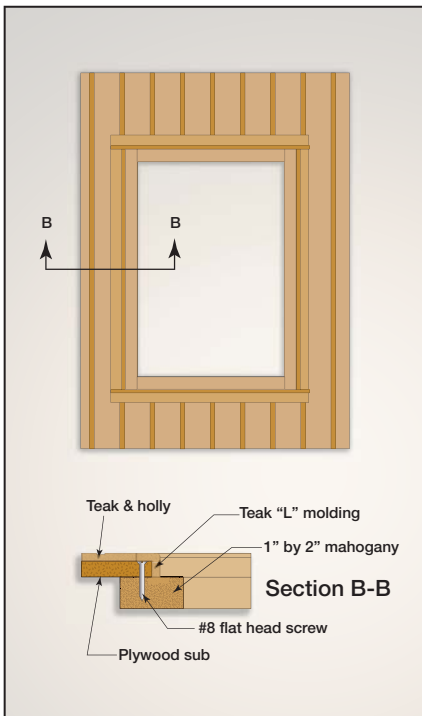

Opening hatch assembly.

edge of molding butts against the teak and holly and the other edge against the cleats, both outer edges of molding were trimmed with a router.

A coped edge on all corners joined the molding ends together inside the opening. To do this, we trimmed one leg of the molding back 1/2" (12mm) and radiused the other leg using a drum sander in a drill press. This was time consuming to do by hand but the results were worth the effort. Molding pieces were then dry fit in the opening. These required hand filing and sanding with coarse paper to get a perfect fit before gluing in place.

The opening was remeasured for the corresponding hatch cover, adding 1/32" gap around the hatch perimeter. After cutting the teak and holly to size, it was glued to the sub floor and moldings attached.

Vee Berth Modifications

After seeing how well this storage area worked out, we chose to add more storage in the vee berth floor using the same method as described above. Storage, however, also required an access door in the bottom to gain access to bilge pumps. Since this access was inside the storage area we simply used painted wood panels with carpet glued to them rather than the teak and holly plywood.

We were able to work on the vee berth floor sections outside the boat because the sections are removable. Floor panels were unscrewed from the stringers and used as templates for the teak and holly pieces. These edges were easier to cap than the dinette storage hatch since coping was not required. [Ed: Coping is a term used in the metal fabricating and woodworking industries to describe a joint where one end has a profile cut

into it that matches exactly the face of the joining piece. Unlike a 45-degree joint, only one of the two pieces to be joined requires shaping.] The teak and holly plywood was simply cut back 1/2" (12mm) from the one exposed edge of the panel creating the notch required for the molding to sit flush. For these panels, the molding and teak and holly plywood were glued into place at the same time.

Once installed into the boat, the opening was measured to determine the size of the hatch. It was important to measure the hatch opening at this point, as opposed to premeasuring the whole thing, due to tolerance issues that occur with adhesive thickness, molding warp and other unforeseeable effects.

Step Assembly

The companionway steps required different considerations. We wanted the look and function of solid wood steps but required the steps to be easily and quickly removable, without the use of tools, to allow access to the engine for service. We decided to build a fixed bottom step and a removable top step and riser, the latter notched into the back of the bottom step to hold it in place. The riser top is secured with spring latches traditionally used for cupboard doors. The top step tabs into the rear bulkhead and locks onto place on the front with a tab behind the riser. Mahogany cleats also support it.

The steps only required capping on three sides and the fourth side of the step was formed into a tab, which locked the step into place under the existing teak moldings. A larger, L-shaped molding was used. Measuring 1-1/4" by

that was accomplished with sandpaper and a utility knife.

The teak molding surfaces were first wiped down with Interlux 216 Reducer to remove the natural oil and ensure a good bond before gluing with Bulldog PL 200. Before clamping, two screws were reinserted to ensure exact line up. Once the glue had cured, we removed the screws and clamps.

The cleats for the hatch to rest upon were cut from 1" by 2" (25mm by 50mm) mahogany. These were glued and screwed into the sub floor. Moldings would later cover these.

We measured the exact opening and cut the molding to length. Since one

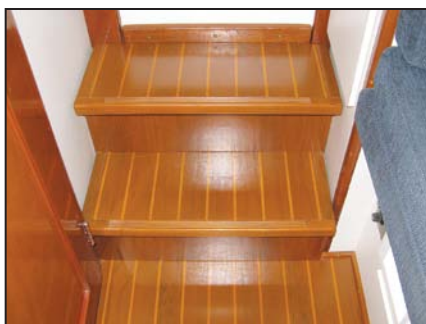

(top) Completed steps. (middle) Traction grooves routed into the edge molding. (bottom) Top step and riser remove for access to storage and the engine.

1-1/4" by 3/8" (31mm by 31mm by 9mm), the larger size allowed us to add grooves for traction at the leading edge using a ball-nose router bit. Molding attachment was the same process as used for the hatch covers other than sinking the molding partially into the step. Also, less material was removed from the molding edge that butt against the teak plywood due to its smaller radius.

Standing the plywood steps vertically on edge and feeding them through a table saw with the fence set at the proper depth created a notch deep enough to allow the top of the molding to sit just a little over-flush with the teak ply.

The risers looked rather plain in comparison to the teak and holly so we opted to cover them with teak veneer

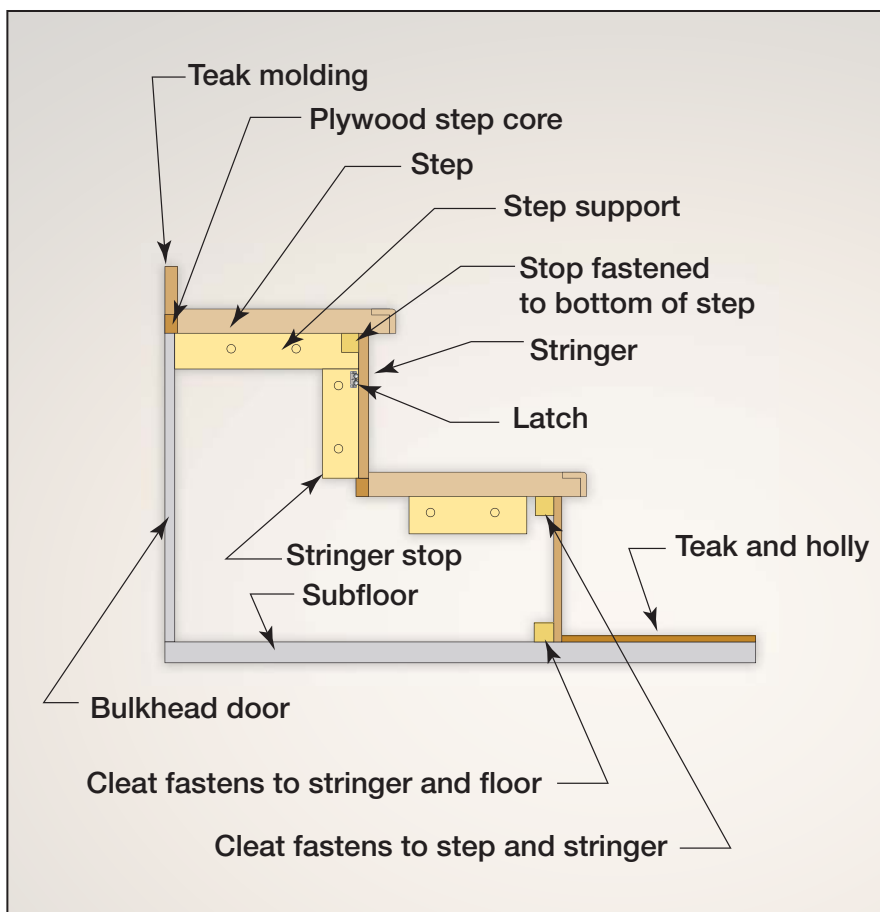

Step and riser construction.

Paul Drouillard/Joe VanVennen

to help tie everything together. Using the existing riser, we simply scuffed the surfaces and brushed a layer of contact cement on all mating surfaces. After the recommended curing time, the two pieces were "clamped" together. Alignment wasn't as critical because the veneer was cut 1" (25mm) larger overall and trimmed to fit with a utility knife after allowing one more day of curing time. When using teak veneer, avoid using latex contact cement due to bleed through. Vapors are toxic so always wear a respirator with the proper filter when using regular contact cement.

The unfinished outer edges were finished with 1/2" (12mm) quarter round molding glued in place. The risers, of course, had to be narrowed by 1" (25mm) to allow space for the quarter round on each side. This was done on a table saw using a fine-tooth blade. This same quarter round was used to finish the edges of the main cabin floor using countersunk flathead screws.

Bulkhead Revamp

The white vinyl-covered bulkheads no longer fit the décor, so we decided to continue the veneer job. This involved removing the vinyl covering, which is easier said than done. Starting at a stapled edge, the staples were removed and a corner peeled back, confirming that it was next to impossible to remove. The vinyl was removed one small strip at a time using a heat-stripping gun and the glue residue was removed using heat and a scraper, one tiny bit at a time. Once all glue was off, the bulkheads were sanded and wiped down with Interlux 216 Reducer. The veneer was then marked out and cut leaving extended edges. Contact cement was applied to all mating surfaces and, using dowels as spacers, the veneer was lined up with the bulkhead. As you're working with high VOC solvents, be sure the area is well ventilated and wear a respirator. Working from one side to the other, the dowels were removed, one at a time, allow-

DIY BILL OF MATERIALS

1 sheet 3/4" (19mm) marine plywood	\$124
2 sheets 1/4" (6mm) teak and holly plywood	\$189
3 rolls, 26" by 100" (660mm by 2.5m) each, teak veneer	\$97
9 pieces, 4' (1.2m) in length teak moldings	\$168
Paint and supplies	\$120
Miscellaneous scrapers, saw blades, screws, adhesives	\$80

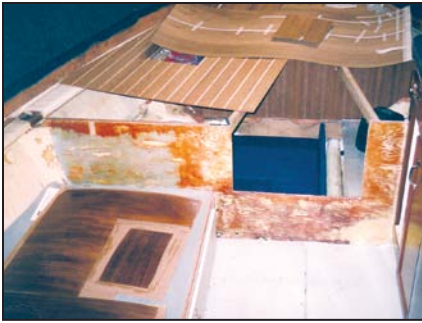

(top) Contact cement is applied to mating surfaces of the bulkhead and the teak veneer. (bottom) Teak veneer glued to bulkhead.

ing the veneer to adhere to the bulkhead. Surfaces were smoothed with a laminate roller to ensure complete adhesion. L-shaped moldings, 1" by 1" (25mm by 25mm) with coped edges, joined the corners.

Finish Choice

Before choosing a wood finish, we asked several people who have boats with teak floors what they used for a coating and not surprisingly, we heard different opinions from every one. Ultimately, Cetol had the look we liked and matched the cabinets.

The floor and steps received four coats of Cetol, sanding between the third and fourth coats with 600-grit paper. This gave a smooth but not slippery surface. The bulkheads and moldings got two coats of Cetol, followed

by two coats of Cetol Gloss. Removable pieces were painted off site and then installed after curing. All pieces bonded in the boat were painted in place.

Once all of the wood was replaced and the interior reinstalled, we couldn't believe the overall difference. It was absolutely worth the effort. It looks great and the new teak surfaces wipe clean effortlessly with a damp rag or mop.

Lessons Learned

As with all one-time projects, hindsight is 20/20. Cutting across the grain on teak and holly plywood was one problem. Whether the edge was taped or not, it chipped when cutting with a power tool. More study of the problem may have led to a solution.

When working with contact cement in early spring, it really is best to ensure you're working within temperatures recommended by the manufacturer. One of the bulkhead veneer panels lifted and wrinkled because of cool temperatures during installation and had to be removed and reglued.

Lastly, we would add more opening clearance to hatch covers as 1/32" all around tends to stick a bit. 🚢

About the author: Paul Drouillard and his wife Margaret spent three years restoring their 1978 Trojan F26 and now spend weekends cruising the islands and marinas in western Lake Erie and Lake St. Clair.

DIY BOAT OWNER
THE MARINE MAINTENANCE MAGAZINE

To subscribe call
1-888-658-BOAT (2628)
diy-boat.com

DIY ON CD-ROM

1995 – 2008
56 Issues of DIY:



A technical reference library for powerboaters and sailboaters. The editorial archives of DIY from 1995 to 2008, from

cover to cover, organized by year and issue.

\$99.95

MRT BOX SET



12 of the MRT Series in a custom vinyl case. Power version has Powerboat Rigging and Sail version has Sailboat Rigging.

\$119.95

(Specify power or sail)

Electronics Connection



Provides the information you need to consider when purchasing, installing, operating, and troubleshooting marine electronics for most any layout or equipment and budget in a step-by-step approach.

\$19.95

DIY BOAT OWNER
THE MARINE MAINTENANCE MAGAZINE

TO ORDER CALL
1-888-658-BOAT
OR SHOP ONLINE AT
WWW.DIY-BOAT.COM

Odor Fatigue

Some ideas for tracking and controlling the microbial critters that produce the malodorous smells wafting from inside your boat.



Story by Roger Marshall

How does your boat smell? Nice and clean? Oily from all the crud that's accumulated in the bilge? Perhaps a little ripe from an odiferous head or holding tank? If you have any of these problems and many boats do, read on.

Let's first consider bilges. If you are a boat owner with immaculate bilges, you are in a minority. On many boats, the bilges are pretty much ignored and when that happens, they will almost always have an odor; the boat's interior probably doesn't smell good either.

What can you do? First, you should determine what ingredients make up the sludge that is in the bilge. In the engine sump, it's probably primarily petrochemicals based in oil and fuel drippings in an emulsion of bilgewater, seasoned with a bunch of other hydrocarbons. Don't pump this stuff out with your bilge pump. The best way to get rid of the mess is to pump it into a can or bottle and dispose of it as hazardous waste. The next step is to put a bilge cleaning formula or product in the area and let it go to work. I prefer the organic type of bilge cleaner, such as Bio-Sok or Clean Water Solutions Oil Eradicator.

Bio-Sok is a petroleum-based remedial product contained in a beeswax-based

material that is packaged in a sausage-shaped tube. Hydrocarbons are attracted to the wax, where they are rendered harmless by the product's other ingredients. When all hydrocarbons are gone or the product is used up, you dispose of the sock at a hazardous waste station.

Clean Water Solutions uses microorganisms in a clay-like mixture that feels like powder. Different types of these tiny organisms are packaged in sponges of varying sizes and chosen based on boat size. To use this product, you simply put the sponge in the bilge and the organisms are activated when the conditions are just right. These tiny little critters eat hydrocarbons, metal particulate and ammonia, and continue feasting on them until all the food is gone or for about 90 days, whichever comes first. At that point, you dispose of the sponge in the trash (the residues are non-toxic) and the job is done. Next step is to track the sources of those nasty fluid leaks to the bilge and eliminate them. Finally, with all the known sources of goo and gunk stopped, paint the bilge with a bright, high-gloss coating (e.g. Interlux BilgeKote) that makes it easy to keep clean.

So much for taking care of the bilges. What about the head compartment?

You've probably flushed the toilet a number of times trying to get rid of the odor but that hasn't worked. That's because you're looking in the wrong place. The smell emanating from most toilets comes from the seawater intake hose. Want proof? Take a rag, wipe the outside of the flush water intake hose and then smell the rag. If it stinks, you've found your culprit. It stinks because the seawater that is drawn into the hose contains microscopic organisms. This water then sits in the hose and head until the next flush, which could be weeks. During summer, when everything is hot in the boat's interior, the microorganisms die off. Eventually, the odor of gazillions of these tiny cadavers seeps through the hose, giving the head its characteristically nauseating smell. The only way to get rid of this odor is to change the intake hose for a less permeable one. Get the best, non-permeable hose you can find. The Shields Poly X Sanitation Hose, available at West Marine, has a lifetime warranty against odor.

It also doesn't hurt to flush the toilet with a mixture of sanitary soap and lanolin. The lanolin lubricates the rubber seals in the head unit, while the sanitary soap cleans the head. At the very least, this job should be done at the end of the season before the boat is winterized. Consult your toilet owner's manual before doing this.

If you suspect that putrid odors are originating from your holding tank, you'll need to first check it for leaks. If you don't find any leaks, have the tank pumped out and thoroughly flushed and then drop in some microtabs from Clean Water Solutions. The microtabs dine on the ammonia byproducts of sewage and minimize the odors emanating from the contents of the holding tank. You can also use 3R Odor-Con, RoeTech or Thetford's Aqua Chem to clean the tank. What you do not want to use are harsh chemicals that can react with the acids in the holding tank to produce potentially dangerous dioxins and trichloromethanes.

Even with treatment, however, the best method to prevent your sanitary system from being a source of foul odors is to pump the holding tank regularly and to flush it well at the end of the season when it's pumped clean. 🍷

About the author: Roger Marshall is the author of 12 books and is currently completing his latest book, *Fiberglass Repair Illustrated*.

With BoatU.S. Insurance, You're Not Just A Number...

"So often in this day and age, customer service representatives are indifferent in their dealings with clients over the phone. I was extremely satisfied with the helpful and courteous way my insurance inquiry was handled and want to thank you for having people of this caliber available for your insurance customers."

*—Bruce Fournier,
Bradenton, FL*

You're Number One!

At BoatU.S., you'll find boating experts with the answers you need when you call. Our knowledgeable Underwriters not only find the perfect coverage for your boat and boating lifestyle, we'll work with you to help find ways to save on your premium. And, as a Berkshire Hathaway company, you can be sure BoatU.S. will be here each and every time you need us.

BoatU.S. Member Bruce Fournier aboard "G'Day" on the Braden River in Florida.

- Low-Cost Policies Developed by Boaters
- Coverage for all Boat Types — Yacht to PWC
- 24/7 Immediate Dispatch of Assistance
- Fast, Fair Claims Service from BoatU.S. Experts



For a fast, free quote call

1-800-283-2883

priority code 4892

or apply online at **BoatUS.com**

Policies Subject to Limits and Exclusions

Uncompromised Engineering,
Unmistakable Elegance.



THE NEW 233SL DUAL BEAM SEARCHLIGHT

Jabco is proud to introduce a one-of-a-kind searchlight that is impressive from all angles. The 233SL Dual Beam Searchlight sports a clean, modern look with a multitude of new features never seen before in a searchlight of this size and price range.



Visit www.jabco.com to learn more